



Content

EQUIPMENT

Rotary & Flated Heat Press

Rotary Heat Press MOT-H	1-2
Rotary Heat Press RTR-H	3-4
Rotary Heat Press BOT-H	5-6
Rotary Heat Press RTR-3226-H	7
Rotary Heat Press MOT-M	8
Rotary Heat Press RTR-M	9
Rotary Heat Press RTR-1732-M	10
Rotary Heat Press SOT	11-12
Rotary Heat Press ROT	13
Rotary Heat Press HS	14
Flatbed Heat Press FOT	15
Flatbed Heat Press FOT-S	16

Fabric Treatment

Textile Fixation TFM	17
Weft Straightening WSM	18
Textile Pre-coating TPM	19

Clamshell Heat Press

Heat Press – Single Plate/Double Plate	20
Heat Press – Mug/Plate/Cup	21

Laser Cutter

Laser Cutter – Edge Tracking	22
Laser Cutter – Mark Point	23

Laminators

Laminator – Professional Level	24
Laminator – Advanced Level	25
Laminator – Entry Level	26
Laminator – Liquid	27
Pouch Laminator	28
Flatbed Applicator – Professional Level	29
Flatbed Applicator – Smart Table	30

Slitter

Fabric Slitter	31
Roll Slitter	32
5m Slitter / Table Slitter	33

Finishing

UV Coater	34
Eyelet Machine / Dies	35
Movable Auto Grommet Machine	35
Welding Machine & Hot Air Welder	36
Cutting Plotter	37
Electrical & Manual Trimmer	38

Packaging

Capsule Filling and Sealing Machine	39-40
Vertical Spiral Stickpack Machine	41-42
Collar Spiral Pouch Packing Machine	43
Rotary Pre-made Pouch Packing Machine	44
Pyramid Tea Bag Machine	45
Drip Coffee Machine	46

FLEXIBLE & RIGID

Flex & Banner

Fabric	47
Dye Sublimation Paper & Tissue Paper	48
PE – Billboard	49
PE – Lightweight – UV	50
PE – Lightweight – Latex	50
PVC Banner – Frontlit	51
PVC Banner – Backlit	51
PVC Banner – Blockout	52
PVC Banner – Mesh	52
PVC Banner – Tarpaulin	53
PET Banner	53

Vinyl & Film

Self-Adhesive Vinyl	54
Cold & Hot Lamination Film	55
One Way Vision & Two Way Vision	56
BOPP Film	57
Reflective Sheeting	58
Reflective Banner/PVC	59
Color Vinyl – 3 Year	60
Color Vinyl – 1 Year	61
Car Wrap Film & Carbon Fiber Vinyl	62
Fluorescent Film & Stencil Film	63
Holographic Film	63
Gold/Silver/Frosted Film	63
Floor Graphic Film & Static Film	64
Luminescent Film	64
Inkjet Media(Dye & Pigment)	65
Inkjet Media(Eco-solvent)	65
Inkjet Media(Dye Ink)	66
Water-proof Inkjet Canvas	67

Rigid

PVC Foam Board	68
PS Foam Core & PS Foam Board	69
Paper PS Foam	70
C-Board / H-Board / V-Board	71
PS Sheet & HIPS Sheet	72
Acrylic Sheet	73
PS Mirror Sheet & PP Hollow Sheet	74
Aluminum Composite Panel	75
Dye Sublimation Board	76
Acoustic Board	77
Wood-Plastic Composite	78
Aluminum Energy-saving Panel	78

DISPLAY

Tension Fabric Display	79
Snake Stand	80-82
Counters and Kiosks	83-84
Overhead Hanging Signs	84
Trade Show Display Packages	85
Textile Fabric Frame & LED Light Frame	86-87
Accessories	87
Canopy Tents	88
Banner Stands	89-91
Brochure Stands	92
Post Stands	93
Outdoor Sign Stands	94
Promotion Counter Display	95-96
Clip Frames	96-97
Pop Up Displays	98
Flying Banners	99

Eastsign

Rotary Heat Press MOT-H

MOT-H Series

- ★ Garments
- ★ Mouse Pad, Carpet
- ★ Flag, Tent, Blanket, Curtain
- ★ Polyester Fabric in Rolls or Piece

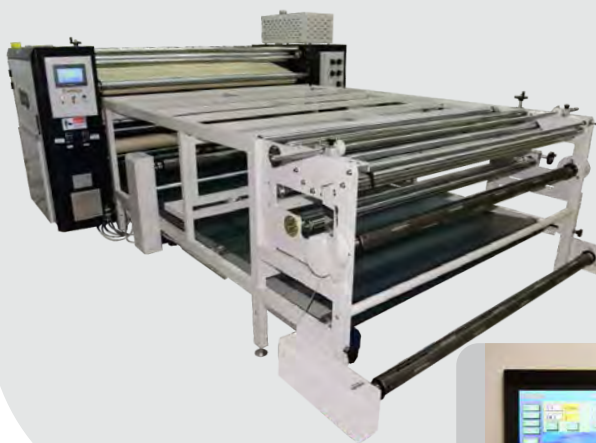

Features

- Aligning Blanket Automatically
- Detecting Temperature on the Surface
- Filling Oil Drum to 100% Full (Saving 30% Power)
- Controlling Temperature Precisely (Controllable Silicon Solid State Relay)
- Minimizing Maintenance Effort (Slip Ring)
- At Least 70% Blanket Coverage
- Blanket Tension Controlled by Piston
- Fabric/Transfer Paper/Tissue Paper Tension Controlled by Compressed Air
- Auto Power On/off
- Touch Screen Control Panel
- User Friendly Operating System
- Real Time Reflection of Transfer Time and Yield

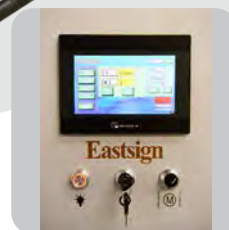

Touch Panel



Power Regulator



PLC



Slip Ring
Maintenance-free



Timer
Auto Power On/off



Rotary Heat Press MOT-H

High End Multi-Functional (Piece-by-Piece or Roll-to-Roll)

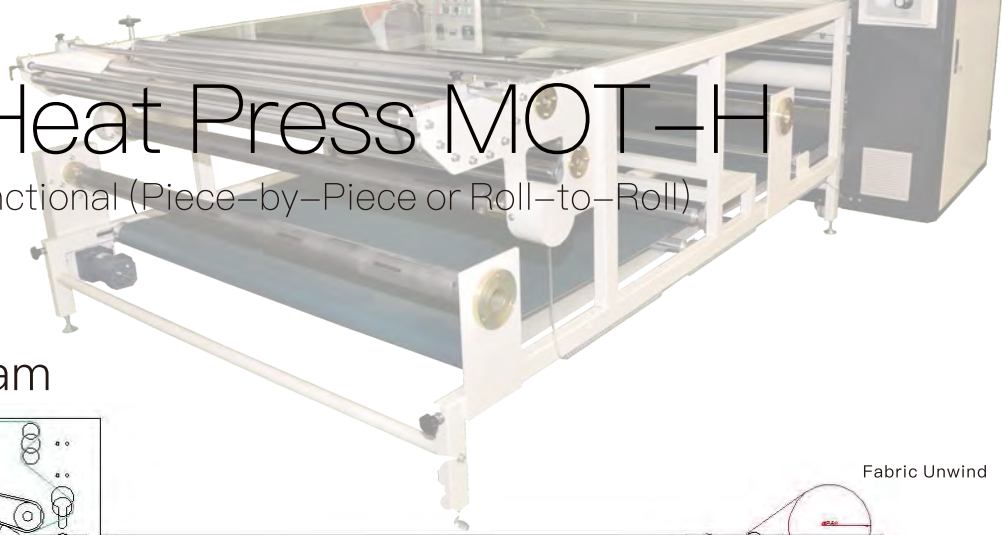

Process Diagram

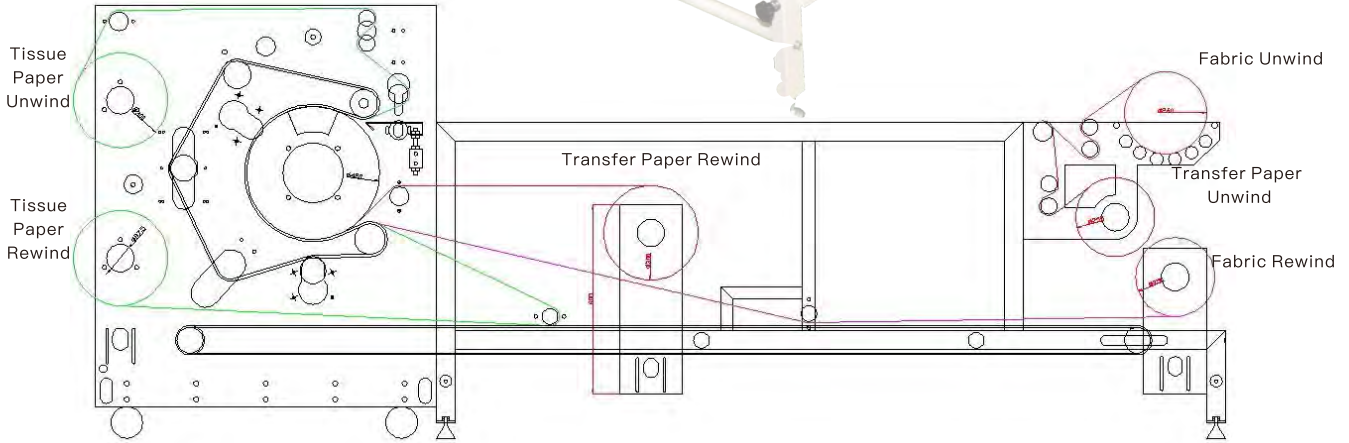

Specifications

Heating Media: Oil, 100% Full
 Heating Elements: 15/27/30/48
 Oil Drum Sizes:



70% Blanket Coverage



- ⌘ Max Temperature: 240°C or 464°F
- ⌚ Transfer Speed: 1.5m/min – Offset Paper: 3m/min
- 🔄 Process Path: Feeding in through Top of Drum
- ⚡ Working Voltage: 3 phase, 220V / 380V / 480V
- ⚡ Rated Power: 26KW (MOT-1742-H)
42KW (MOT-2742-H)
50KW (MOT-3242-H)

Model	Machine Dimension	Working table Size
MOT-1742H	2450mm x 985mm x 1820mm 96" x 39" x 72"	1860mm x 1920mm x 1010mm 73" x 75" x 40"
MO7-2642H	3290mm x 985mm x 1820mm 130" x 39" x 72"	2860mm x 1920mm x 1010mm 113" x 75" x 40"
MOT-3242H	4010mm x 985mm x 1820mm 158" x 39" x 72"	3360mm x 1920mm x 1010mm 132" x 75" x 40"

- ◆ Air Compressor: Optional
- ◆ Blanket and Oil Drum are not under warranty
- ◆ Other parts are eligible for 15 months warranty under proper use (starting from the time of ex factory)



Eastsign

Rotary Heat Press RTR-H

RTR-H Series

- ★ Garments
- ★ Carpet
- ★ Flag, Tent, Blanket, Curtain
- ★ Polyester Fabric in Rolls



Features

- Aligning Blanket Automatically
- Detecting Temperature on the Surface
- Filling Oil Drum to 100% Full (Saving 30% Power)
- Controlling Temperature Precisely (Controllable Silicon Solid State Relay)
- Minimizing Maintenance Effort (Slip Ring)
- At Least 70% Blanket Coverage
- Blanket Tension Controlled by Piston
- Fabric/Transfer Paper/Tissue Paper Tension Controlled by Compressed Air
- Auto Power On/off
- Touch Screen Control Panel
- User Friendly Operating System
- Real Time Reflection of Transfer Time and Yield

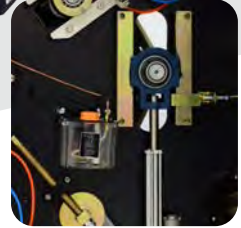

Belt Auto-aligning



Power Regulator



PLC



Slip Ring
Maintenance-free



Timer
Auto Power On/off



Rotary Heat Press RTR-H

High End Roll-to-Roll



Process Diagram

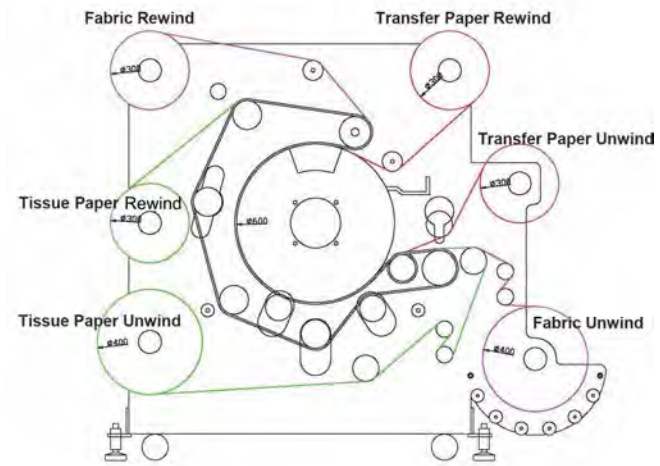

Specifications

Heating Media: Oil, 100% Full

Heating Elements: 15/27/30/48

Oil Drum Sizes:



70% Blanket Coverage



- ⌘ Max Temperature: 240°C or 464°F
- ⌚ Transfer Speed: 1.5m/min – Offset Paper: 3m/min
- ⌘ Process Path: Feeding in through Bottom of Drum
- ⌚ Working Voltage: 3 phase, 220V / 380V / 480V
- ⌚ Rated Power: 26KW(RTR-1742-H)
42KW(RTR-2642-H)
50KW(RTR-3242-H)

Model	Machine Dimension
RTR-1742-H	2550mm x 1400mm x 2000mm 100" x 55" x 79"
RTR-2742-H	3200mm x 1400mm x 2000mm 134" x 55" x 79"
RTR-3242-H	4100mm x 1400mm x 2000mm 161" x 55" x 79"

- ◆ Air Compressor: Optional
- ◆ Blanket and Oil Drum are not under warranty
- ◆ Other parts are eligible for 15 months warranty under proper use (starting from the time of ex factory)

Eastsign

Rotary Heat Press BOT-H

BOT-H Series

- ★ Garments
- ★ Mouse Pad, Carpet
- ★ Flag, Tent, Blanket, Curtain
- ★ Polyester Fabric in Rolls or Piece

Features

- Aligning Blanket Automatically
- Detecting Temperature on the Surface
- Filling Oil Drum to 100% Full (Saving 30% Power)
- Controlling Temperature Precisely (Controllable Silicon Solid State Relay)
- At Least 70% Blanket Coverage
- Daily Power On/off
- Touch Screen Control Panel
- User Friendly Operating System
- Real Time Reflection of Transfer Time and Yield
- Cut piece collection at the back of the machine.
- No Large Floor Space Required
- Unwind & Rewind Operating Works Independently without Interference

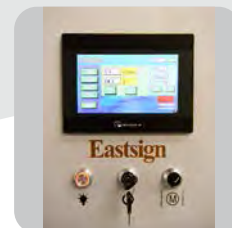

Touch Panel



Power Regulator



PLC



Slip Ring
Maintenance-free



Timer
Auto Power On/off



Rotary Heat Press BOT-H

High End Multi-Functional (Piece-by-Pie or Roll-to-Roll)

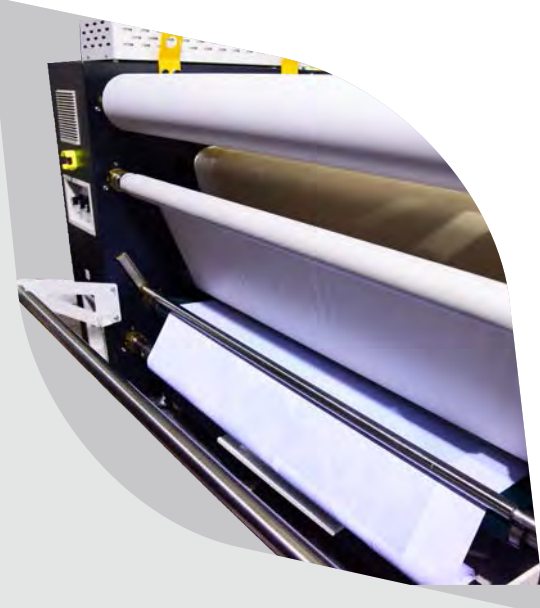
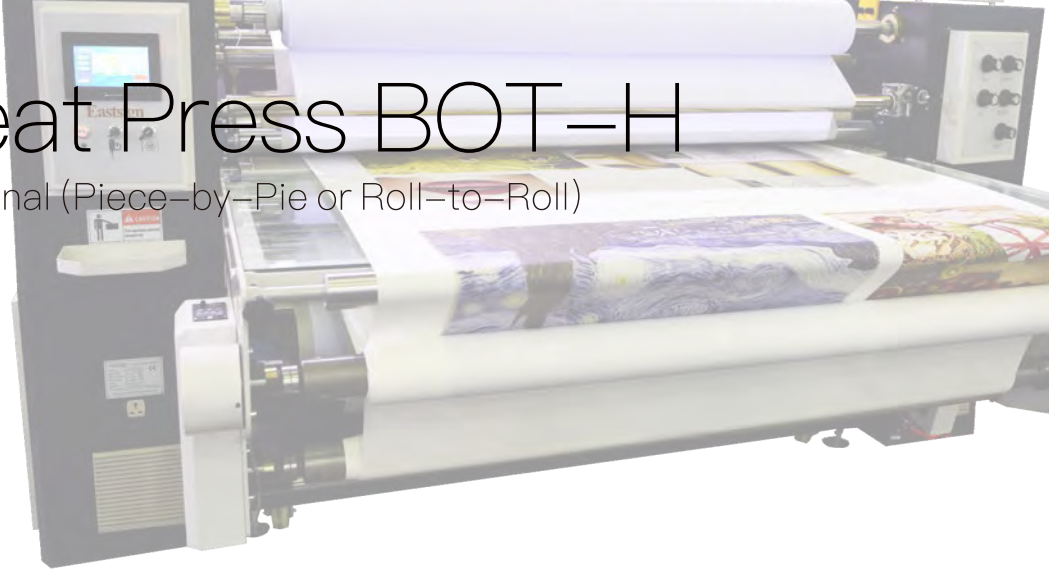

Process Diagram

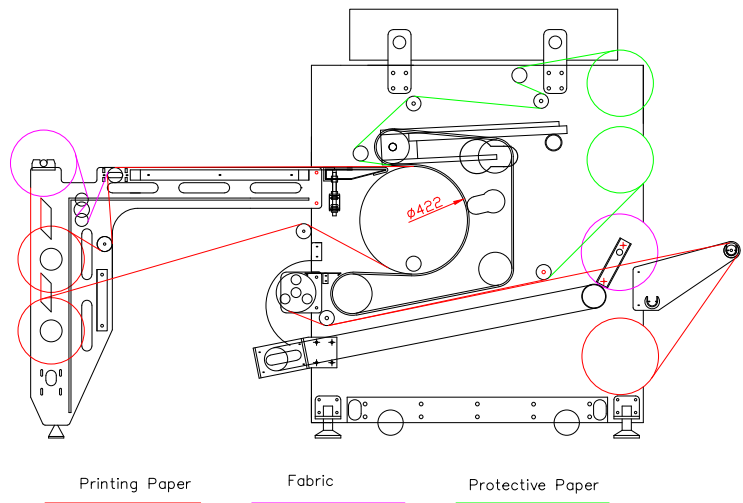

Specifications

Heating Media: Oil, 100% Full

Heating Elements: 9/15/27

Oil Drum Sizes:



⚗ Max Temperature: 240°C or 464°F

⌚ Transfer Paper: 0.5-1.5m/min

🌀 Process Path: Feeding in through Top of Drum

⚡ Working Voltage: 3 phase, 220V / 380V / 480V

⚡ Rated Power: 23KW/26KW/46KW



Model	BOT-1742-H
Transfer Width	1600mm or 63"
Felt Width	1700mm or 67"
Machine Dimension	2950mm x 1560mm x 1820mm or 116" x 62" x 72"
Working table Size	1900mm x 960mm x 1100mm or 75" x 38" x 43"
Packing Size	3150mm x 1800mm x 2100mm or 124" x 71" x 83"
Net Weight	2400kg or 5291lb
Gross Weight	2650kg or 5843lb

◆ Air Compressor: Optional

◆ Blanket and Oil Drum are not under warranty

◆ Other parts are eligible for 15 months warranty under proper use (starting from the time of ex factory)

Eastsign

Rotary Heat Press RTR-3226-H

High End Roll-to-Roll Sublimation Machine

RTR-3226-H

- ★ Garments
- ★ Mouse Pad, Carpet
- ★ Flag, Tent, Blanket, Curtain
- ★ Polyester Fabric in Rolls or Piece

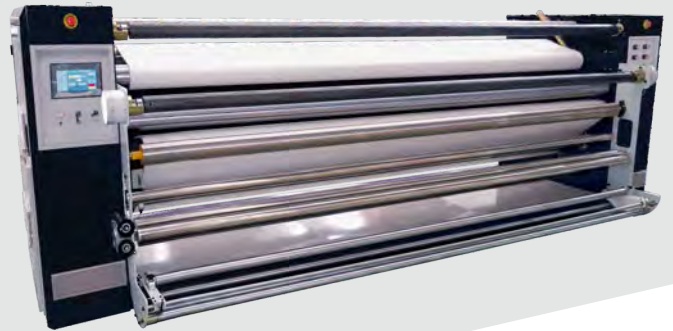

Features

- Detecting Temperature on the Surface
- Filling Oil Drum to 100% Full (Saving 30% Power)
- Controlling Temperature Precisely (Controllable Silicon Solid State Relay)
- Minimizing Maintenance Effort (Slip Ring)
- At Least 70% Blanket Coverage
- Fabric/Transfer Paper/Tissue Paper Tension Controlled by Compressed Air
- Auto Power On/off
- Touch Screen Control Panel
- User Friendly Operating System
- Real Time Reflection of Transfer Time and Yield



Power Regulator



Slip Ring
Maintenance-free

Specifications

Heating Media: Oil, 100% Full

Heating Elements: 9

Oil Drum Sizes:



75% Blanket Coverage

- ⌘ Max Temperature: 240°C or 464°F
- ⌚ Transfer Speed: 1m/min – Offset Paper: 2m/min
- ⌘ Process Path: Feeding in through Bottom of Drum
- ⌚ Working Voltage: 3 phase, 220V / 380V / 480V
- ⌚ Rated Power: 19KW

Model	RTR-3226-H
Transfer Width	3200mm or 126"
Felt Width	3300mm or 130"
Machine Size	4400mm x 1500mm x 1700mm 172" x 59" x 67"
Weight	2550Kg

- ◆ Air Compressor: Optional
- ◆ Blanket and Oil Drum are not under warranty
- ◆ Other parts are eligible for 15 months warranty under proper use (starting from the time of ex factory)



Eastsign

Rotary Heat Press MOT-M

Middle Class Multi-Functional(Piece-by-Piece or Roll-to-Roll)

MOT-M Series

- ★ Garments
- ★ Mouse Pad, Carpet
- ★ Flag, Tent, Blanket, Curtain
- ★ Polyester Fabric in Rolls or Piece



Features

- Rotary Heat Press for Roll-to-Roll or Piece-by-Piece
- Three Feeding Rolls and Two Take-up Rolls
- Duplex Teflon Oil Drum
- Air Expanding Shaft Included
- Hand Crank Blanket Tension
- Blanket Release System
- Max width: 3.2m or 126"
- Transfer Pressure System

Specifications

Heating Media: Oil, 50% Full

Heating Elements: 15/27/30/48

Oil Drum Sizes:

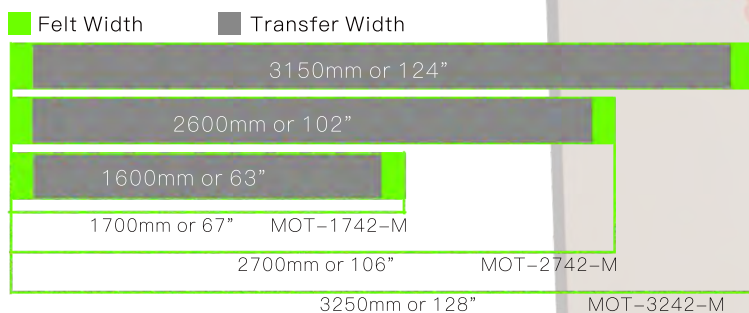

- 🔧 Max Temperature: 240°C or 464°F
- ⌚ Transfer Speed: 1.5m/min – Offset Paper: 2.5m/min
- 🔄 Process Path: Feeding in through Top of Drum
- ⚡ Working Voltage: 3 phase, 220V / 380V / 480V
- ⚡ Rated Power: 26KW(MOT-1742-M)
41KW(MOT-2742-M)
48KW(MOT-3242-M)

Model	MOT-1742-M	MOT-2742-M	MOT-3242-M
Machine Dimension	2450mm x 985mm x 1320mm 96" x 39" x 51"	3290mm x 985mm x 1320mm 130" x 39" x 51"	4010mm x 985mm x 1320mm 158" x 39" x 51"
Working table Size	1860mm x 1920mm x 970mm 73" x 75" x 38"	2860mm x 1920mm x 970mm 113" x 75" x 38"	3360mm x 1920mm x 970mm 132" x 75" x 38"
Packing Size	2650mm x 1300mm x 1630mm 104" x 51" x 64"	3600mm x 1300mm x 1630mm 141" x 51" x 64"	4300mm x 1300mm x 1630mm 169" x 51" x 64"
Net Weight	1500kg or 3300lb	1700kg or 3740lb	1800kg or 3960lb
Gross Weight	1650kg or 3630lb	1900kg or 4180lb	2000kg or 4400lb

- ◆ Blanket and Oil Drum are not under warranty
- ◆ Other parts are eligible for 15 months warranty under proper use (starting from the time of ex factory)

Eastsign

Rotary Heat Press RTR-M

Middle Class (Roll-to-Roll)

RTR-M Series

- ★ Garments
- ★ Mouse Pad, Carpet
- ★ Flag, Tent, Blanket, Curtain
- ★ Polyester Fabric in Rolls or Piece

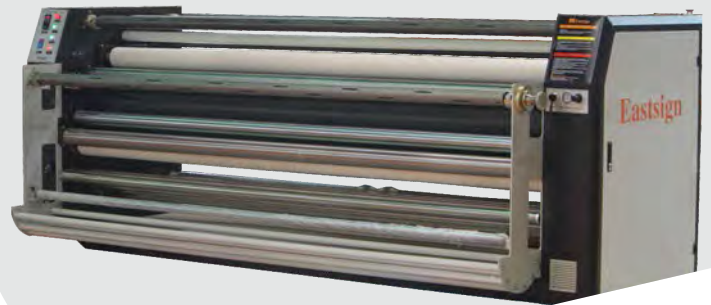

Features

- 50% Full Oil Drum
- 3 Tensioning System
- 3 Pairs of Feeding and Take-up Rolls
- Teflon Coating Oil Drum
- Air Expanding Shaft Included
- Hand Crank Blanket Tension
- Blanket Release System
- Max width: 3.2m or 126"
- Transfer Pressure System

Specifications

Heating Media: Oil, 50% Full

Heating Elements: 15/27/30/48

Oil Drum Sizes:

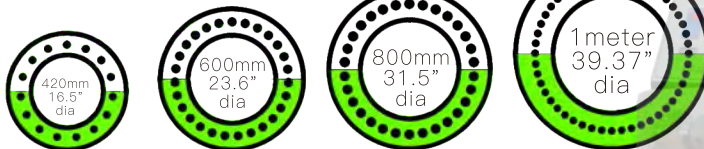

- 🔧 Max Temperature: 240°C or 464°F
- ⌚ Transfer Speed: 1.5m/min – Offset Paper: 2.5m/min
- 🔄 Process Path: Feeding in through Bottom of Drum
- ⚡ Working Voltage: 3 phase, 220V / 380V / 480V
- ⚡ Rated Power: 26KW(RTR-1742-M)
41KW(RTR-2642-M)
48KW(RTR-3242-M)

Model	RTR-1742-M	RTR-2742-M	RTR-3242-M
Machine Dimension	2550mm x 1400mm x 1500mm 100" x 55" x 59"	3400mm x 1400mm x 1500mm 134" x 55" x 59"	4100mm x 1400mm x 1500mm 161" x 55" x 59"
Packing Size	2650mm x 1700mm x 1850mm 104" x 67" x 73"	3550mm x 1700mm x 1850mm 140" x 67" x 73"	4200mm x 1700mm x 1850mm 165" x 67" x 73"
Net Weight	1500kg or 3300lb	1700kg or 3740lb	1800kg or 3960lb
Gross Weight	1650kg or 3630lb	1900kg or 4180lb	2000kg or 4400lb

- ◆ Blanket and Oil Drum are not under warranty
- ◆ Other parts are eligible for 15 months warranty under proper use (starting from the time of ex factory)

Eastsign

Rotary Heat Press RTR-1732-M

Middle Class Multi-Functional(Piece-by-Piece or Roll-to-Roll)

RTR-1742-M

- ★ Garments
- ★ Mouse Pad, Carpet
- ★ Flag, Tent, Blanket, Curtain
- ★ Polyester Fabric in Rolls or Piece



Features

- Rotary Heat Press for Roll-to-roll or Piece-by-piece
- 3 Tensioning System
- 3 Pairs of Feeding and Take-up Rolls
- Teflon Oil Drum
- Hand Crank Blanket Tension
- Blanket Release System
- Transfer Pressure System
- Additional Working table available

Specifications

Heating Media:Oil, 50% Full

Heating Elements:9

Oil filled drum sizes:320mm or 12.6" , Double-Layer



- ⌘ Max Temperature:240°C or 464°F
- ⌚ Transfer Speed:1.2m/min – Offset Paper: 2m/min
- ⌘ Process Path:Feeding in through Top or Bottom of Drum
- ⚡ Working Voltage:3 phase, 220V / 380V / 480V
- ⚡ Rated Power: 15KW



Model	RTR-1732-M
Transfer Width	1600mm or 63"
Felt Width	1700mm or 67"
Machine Dimension	2600mm x 1300mm x 1400mm 103" x 51" x 55"
Packing Size	2680mm x 1700mm x 1850mm 106" x 67" x 73"
Net Weight	1400kg or 3087lb
Gross Weight	1600kg or 3528lb

- ◆Blanket and Oil Drum are not under warranty
- ◆Other parts are eligible for 15 months warranty under proper use(starting from the time of ex factory)

Eastsign

Rotary Heat Press SOT

SOT-H Series

- ★ Garments
- ★ Flag, Blanket, Curtain
- ★ Any Polyester in Rolls or Sheets
- ★ Fixation



Features

- Aligning Blanket Automatically
- 3 Pairs of Feeding and Take-up Rolls
- Oil Drum, 200mm or 7.9"
- Working Width: 1.22m / 1.6m or 48" / 64"
- Manual Blanket Release System by Hand Crank
- Rotary Heat Press for Making Dye Sublimation Heat Transfer Sample



Rotary Heat Press SOT

Entry Level (Piece-by-Piece or Roll-to-Roll)



Process Diagram

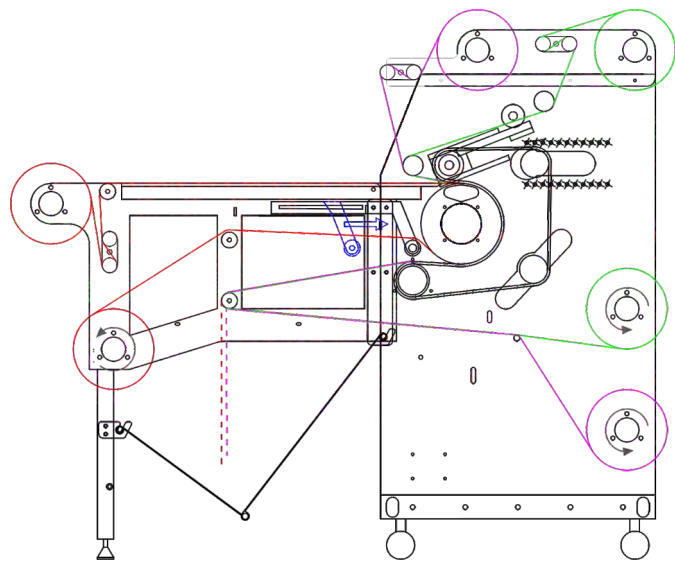

Specifications

Heating Media: 50% Oil
 Heating Elements: 3 or 6
 Oil Drum Sizes: 200mm or 7.8"

- 🔧 Max Temperature: 240°C or 464°F
- ⌚ Transfer Speed: up to 0.5m/min or 5.4'/min
- 🔄 Process Path: Feeding in through Top of Drum
- ⚡ Working Voltage: Single phase, 220V
- ⚡ Working Power: 4.5KW/9KW

Model	SOT-44/SOT-44H	SOT-64/SOT-64H
Auto Felt Alignment	No/Yes	No/Yes
Machine Dimension	1850mm x 660mm x 1250mm 73" x 26" x 50"	2450mm x 720mm x 1300mm 96" x 28" x 51"
Working table Size	1630mm x 800mm x 950mm 64" x 32" x 38"	1900mm x 620mm x 680mm 75" x 25" x 27"
Packing Size	2010mm x 850mm x 1520mm 79" x 34" x 60"	2640mm x 950mm x 1600mm 104" x 38" x 63"
Gross Weight	600kg or 1323lb	984kg or 2170lb

- ◆ Air Compressor: Optional
- ◆ Blanket and Oil Drum are not under warranty
- ◆ Other parts are eligible for 15 months warranty under proper use (starting from the time of ex factory)

Eastsign

Rotary Heat Press ROT Ribbon Application(Roll-to-Roll)

ROT Series

- ★ Ribbon
- ★ Lanyard
- ★ Polyester in Roll



Specifications

 Model	ROT-300-S
Heating Media	Oil, 50% Full
Voltage	Single Phase, 220V or 3Phase, 220V/ 380V
Power	3KW
Heating Elements	6
Diameter of Drum	300mm or 11.8"
Transfer Speed	up to 1.5m/min or 4.9'/min
Max Temperature	240°C or 464°F
Transfer Width	250mm or 9.8"
Spacers	10

Heating Media:Oil
Heating Elements:12
Oil filled drum sizes:

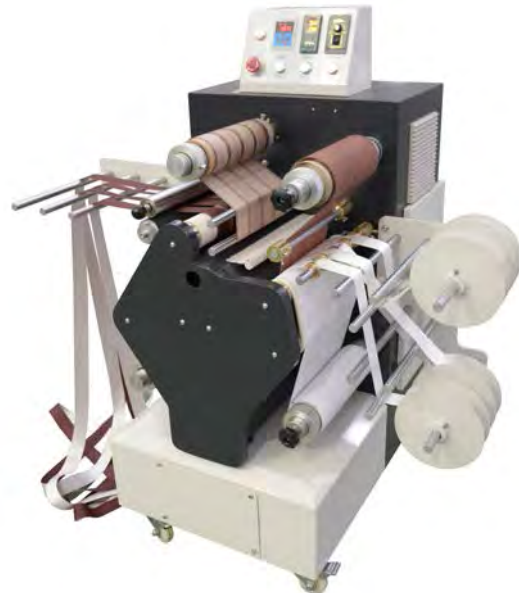

ROT-300S

- ⌘ Max Temperature:240°C or 464°F
- ⌚ Transfer Speed:Up to1.5m/min
- 🔄 Process Path:Feeding in through Top of Drum
- ⚡ Working Voltage:3 phase, 220V / 380V / 480V

 Model	ROT-942	ROT-1242
Heating Power (Pre-heat)	14kW	18kW
Heating Power (Working)	10 kW	13kW
Transfer Width of Lanyard	600mm	900mm
Transfer Width of Garment	800mm	1100mm
Spacers	40	
Machine Dimension	3000mm x 1660mm x 1900mm 118" x 65" x 75"	3000mm x 1960mm x 1900mm 118" x 77" x 75"
Packing Size	2100mm x 1500mm x 1700mm 83" x 59" x 67"	2400 x 1500 x 1700mm 94" x 59" x 67"
Net Weight	950kg or 2094lb	1150kg or 2535lb

- ◆ Blanket and Oil Drum are not under warranty
- ◆ Other parts are eligible for 15 months warranty under proper use(starting from the time of ex factory)

Eastsign

Rotary Heat Press HS

Industrial Level(Roll-to-Roll)

HS Series

- ★ Garments
- ★ Mouse Pad, Carpet
- ★ Flag, Tent, Blanket, Curtain
- ★ Polyester Fabric in Rolls



Features

- Chromium coated Oil drum
- Detecting Temperature on the Surface
- Controlling Temperature Precisely (Controllable Silicon Solid State Relay)
- Blanket coverage at least 80%
- Fabric/Transfer Paper/Tissue Paper Tension Controlled by Compressed Air
- Daily Power On/off
- Over-feeding System for Spandex
- Fabric Cooling System
- Fabric Water Cooling (optional)
- Electric Crane (optional)
- Aligning Material and Felt Automatically
- Blanket Tension Controlled by Piston
- User-friendly Interface with Touch Screen
- Width Expanding System
- High-end Fabric Aligning System (optional)
- Fabric Discharge Swinging System (optional)

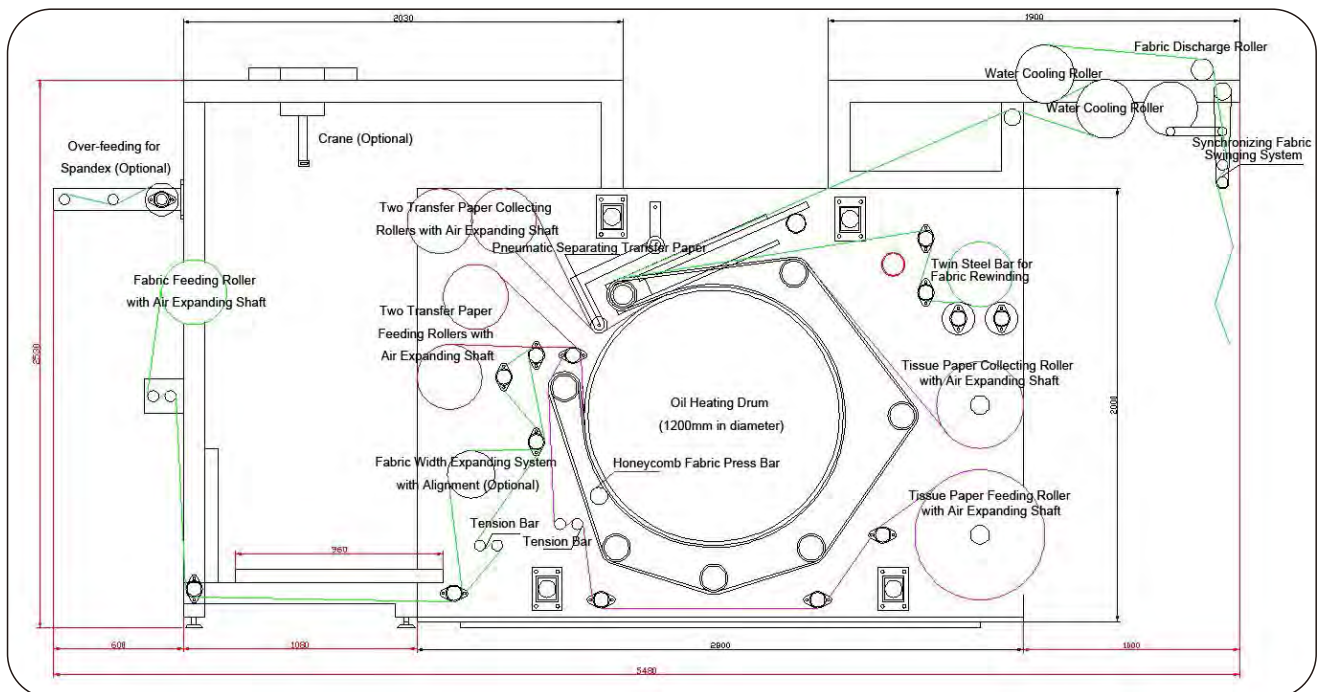

Specifications

	Model	HS-17120
	Heating Media	Oil, Almost 50% Full
	Voltage	3Phase 380V
	Power	95kW
	Heating Elements	51
	Diameter of Drum	1200mm (Available in 800mm/1000mm/1500mm)
	Transfer Speed	3-15m/min
	Max Temperature	230°C or 446°F
	Transfer Width	1700mm
	Felt Width	1880mm
	Process Path	Feeding in through Bottom of Drum
	Air Compressor	Required, But Air Compressor not Included
	Machine Dimension	5300mm x 3300mm x 2500mm
	Net Weight	7500kg

- ◆ Air Compressor: Optional
- ◆ Blanket and Oil Drum are not under warranty
- ◆ Other parts are eligible for 15 months warranty under proper use (starting from the time of ex factory)



Eastsign

Flatbed Heat Press FOT Standard Version

FOT Series

- ★ T-shirt, Towel
- ★ Mouse Pad, Carpet
- ★ Flag, Blanket, Coated Aluminum Sheet
- ★ Polyester Fabric in Piece



Features

- Double Shuttles for Saving Working Time
- Alternative Way of Working, Auto or Manual
- Distributing Temperature and Pressure Evenly
- Strong Hydraulic Pressure Allows Deep Ink Penetration
- Maximum Size: 1.22m x 2.44m or 48" x 96"
- Other sizes can be customized upon request



Control Panel



Operation Panel



Pressure Gauge

Specifications

Model	FOT-1224	
Voltage	3 Phase, 220V	3 Phase, 380V
Heating Power	34kW	38kW
Number of Heating Element	24	
Total Power	34kW	38kW
Types	Single Side Heating	
Max Temperature	260°C or 500°F	
Transfer Size (L X W)	1150mm x 2350mm or 45" x 92"	
Machine Dimension	5800mm x 1800mm x 1900mm or 229" x 71" x 75"	
Net Weight	3500kg or 7700lb	



FOT-1224

Heating Media: Electric

Number of Heating Element:

⌘ Max Temperature: 240°C or 464°F

⚡ Rated Voltage: 3 phase, 220V / 380V / 480V

Model	FOT-1012	FOT-1015	FOT-1012D	FOT-1015D
Heating Power	16 kW	24 kW	31kW	38kW
Number of Heating Element	12	12	24	24
Types	Single Side Heating		Double Side Heating	
Transfer Size (L X W)	1000mm x 1200mm 39" x 47"	1000mm x 1500mm 39" x 59"	1000mm x 1200mm 39" x 47"	1000mm x 1500mm 39" x 59"
Machine Dimension	2300mm x 1500mm x 1400mm 90" x 59" x 55"	2300mm x 1800mm x 1400mm 90" x 70" x 55"	2300mm x 1500mm x 1550mm 90" x 59" x 61"	2300mm x 1800mm x 1550mm 90" x 70" x 61"
Packing Size	2500mm x 1700mm x 1700mm 98" x 67" x 67"	2500mm x 2000mm x 1700mm 98" x 79" x 67"	2500mm x 1700mm x 1850mm 98" x 67" x 73"	2500mm x 2000mm x 1850mm 98" x 79" x 73"
Net Weight	950kg or 2090lb	1100kg or 2420lb	1250kg or 2750lb	1400kg or 3080lb
Gross Weight	1050kg or 2310lb	1250kg or 2750lb	1350kg or 2970lb	1550kg or 3410lb

◆ Blanket and Oil Drum are not under warranty

◆ Other parts are eligible for 15 months warranty under proper use (starting from the time of ex factory)

Eastsign

Flatbed Heat Press FOT-S Economic Version

FOT Series

- ★ T-shirt, Towel
- ★ Mouse Pad, Carpet
- ★ Flag, Blanket, Ski
- ★ Polyester Fabric in Piece



Features

- Three-way Open Shuttle for Making Long Fabric
- Distributing Temperature and Pressure Evenly
- Strong Pneumatic Pressure Allows Deep Ink Penetration
- Max Size: 1.10m x 1.70m or 43" x 67"
- Simple Mechanical Design – Easy for Maintenance



Specifications

Model	FOT-1012-S	FOT-1215-S
Heating Media	Stainless Steel Heating Plate, Single Side Heating	
Heating Plate	12pcs	15pcs
Voltage	3 Phase, 220V / 380V / 480V	
Power	15KW	24KW
Max Temperature	240°C or 428°F	
Transfer Size	900mm x 1100mm 35" x 43"	1100mm x 1400mm 43" x 55"

- ◆ Stainless Steel Plate is not under warranty
- ◆ Air compressor is not included
- ◆ Air cylinder and other parts are eligible for 1 year warranty under proper use(starting from invoice date)

Eastsign

Textile Fixation TFM

Roll-to-Roll

TFM-M Series

- ★ Garments
- ★ Flag, Tent, Blanket, Curtain
- ★ Polyester Fabric in Rolls



Features

- Economic version heat press, special design for fixation.
- No belt required
- Detecting temperature on the surface.
- Controlling temperature precisely.
- Roll to Roll.
- Constant tension for materials rewind.
- Machine can be off immediately at day's end, without taking more time for cooling machine.
- At Least 80% materials coverage during fixation procedure.

Specifications

Heating Media: Oil, 50% Full

Heating Elements: 9

Oil Drum Sizes: 260mm or 10.2", Double-Layer



- 🔧 Max Temperature: 230°C or 446°F
- ⌚ Transfer Speed: 0.1–4m/min
- 🔄 Process Path: Feeding in through Top of Drum
- ⚡ Working Voltage: 3 phase, 220V / 380V / 480V
- ⚡ Rated Power: 18KW(TFM-1700)
23KW(TFM-3200)



Model	TFM-1700	TFM-3200
Transfer Width	1600mm	3200mm
Max Loading Diameter	350mm	350mm
Machine Dimension	2550mm x 1400mm x 2000mm 100" x 55" x 79"	4100mm x 1050mm x 1420mm 161" x 41" x 55"

- ◆ Air Compressor: Optional
- ◆ Blanket and Oil Drum are not under warranty
- ◆ Other parts are eligible for 15 months warranty under proper use (starting from the time of ex factory)

Eastsign

Weft Straightening WSM

Roll-to-Roll

WSM Series

- ★ Polyester Fabric in Rolls
- ★ Knitted fabric
- ★ Chiffon



Features

- High performance, Cost-effective.
- Newly-developed detector, suitable for variety materials and high detection accuracy
- Dual Mode Bias-Weft detection: Infrared Reflection and High Concentration Light Bulb Projection.
- The detector can be adjusted freely according to the width of the materials.
- Touch screen control.
- Variable frequency drive with higher motion sensitivity and precision.

Applications

- To be use combine with Digital printing machine or pre-coating machine.
- Available for various materials, such as Silk, chiffon, chemical fiber, cotton, shade cloth, knitted fabric, flannel, woolen and so on..

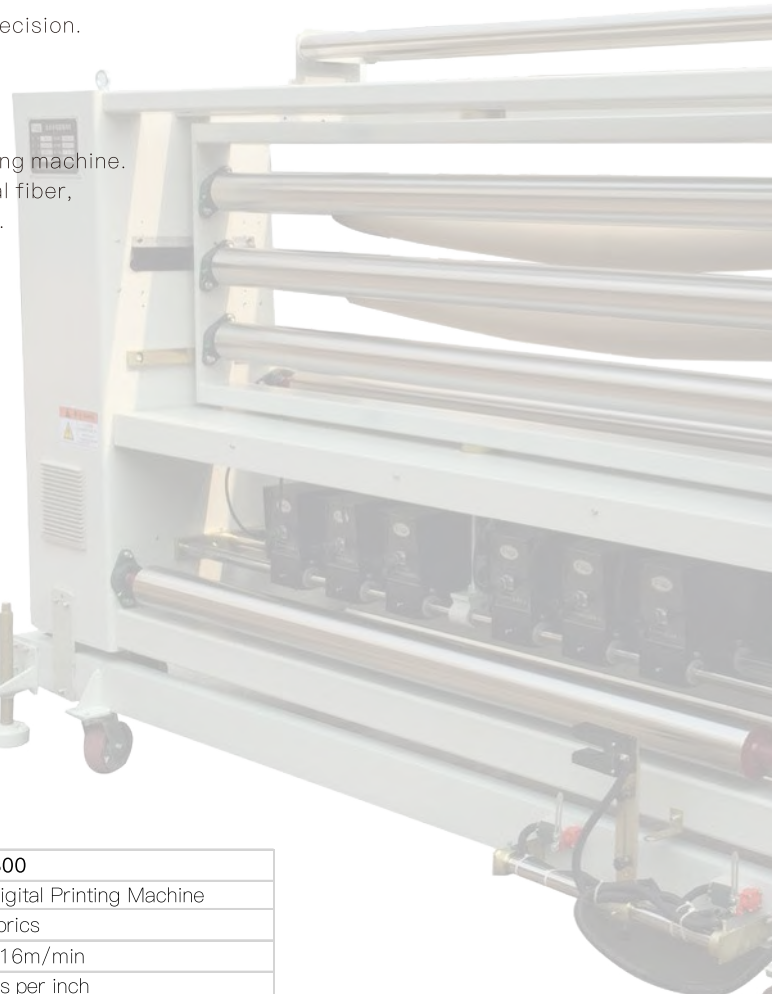

Specifications

Model	WSM-1800
Installation Site	Materials Feeding Stage of Digital Printing Machine
Application	Woven Fabrics
Mechanical Speed	Active Type, 1~16m/min
Bias-Weft Detection	10~350 Threads per inch
Capability of Weft Straightening	Bias-Weft $< \pm 20\%$ of the width of materials, within 450mm
Quantity of Sensors	4~6 Sets
Signal Acquisition Method	Infrared Reflection or High Concentration Light Bulb Projection
Angle Detection	$\pm 19^\circ$ in maximum
Detecting Precision	$\pm 0.1^\circ$

- ◆ Blanket and Oil Drum are not under warranty
- ◆ Other parts are eligible for 15 months warranty under proper use (starting from the time of ex factory)

Eastsign

Textile Pre-coating TPM

Roll-to-Roll

TPM-1800

- ★ Flag / Curtain
- ★ Blanket / Towel
- ★ Cotton / Polyester / Silk in Rolls



Features

- Adding Coating Before Heat Transfer or Direct Printing
- Making Fabric More Glossy
- Auto-rectifying System to Guide the Feeding of Textile
- Drying and Stabilizing Fabric Instantly

Process Diagram

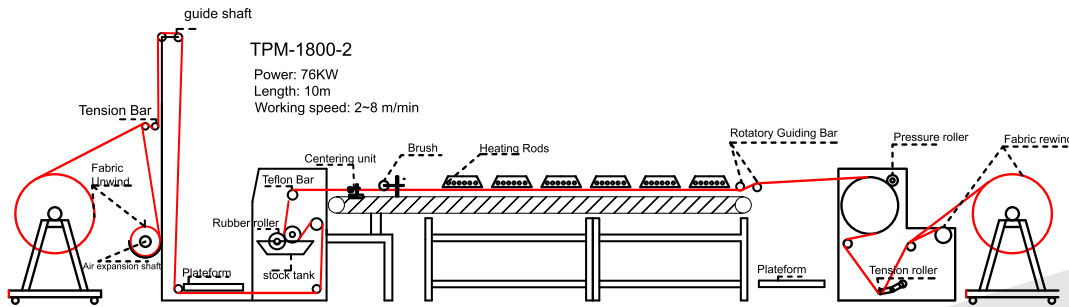

Specifications

Model	TPM-1800
Coating Width	1800mm or 71"
Heating Chamber	1 Chambers 18 pcs Quartz Infra-red Heating Element per Each Chamber, 36kW
Oil Heating Calander Drum	Drum Size: 370mm or 14.5", 15kW
Total Power	39kW
Weight	2000kg or 4400lb
Machine Size	6800mm x 2680mm x 1900mm 268" x 106" x 75"
Heating Chamber	Speed (Cotton 130gsm)
1	1.5m or 4.9' per minute
2	3m or 9.8' per minute
3	4m or 13.1' per minute

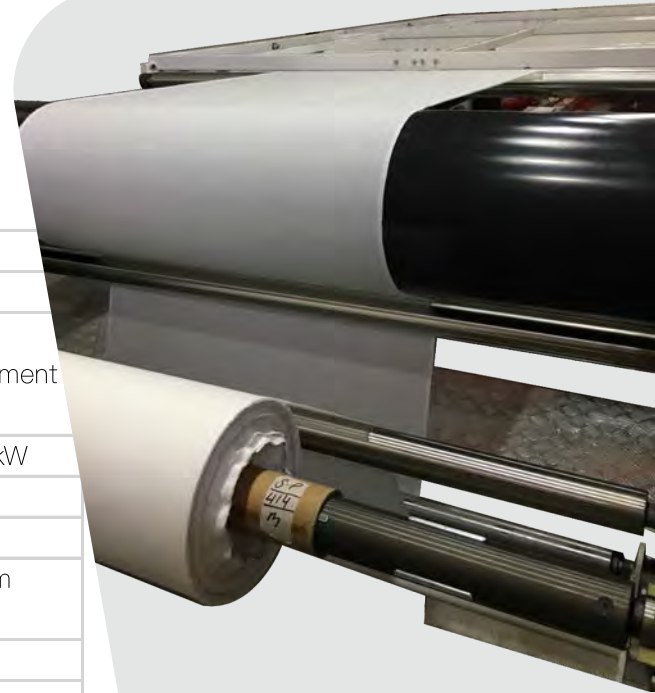

◆ Blanket and Oil Drum are not under warranty

◆ Other parts are eligible for 15 months warranty under proper use (starting from the time of ex fa

Eastsign

Heat Press – Single Plate

Features

- Perfect in Transferring T-Shirt, Socks, Garment, Blanket, Etc.
- Power Saving, Accuracy and Flexibility
- Distributing Heat evenly by Advanced Heating Component
- Single Chip Processor, LCD Display, PID Accounting Device and PWM Output Design
- Integrated Electrical Control System
- Convenient Adjustment and Maintenance
- Substrate Would not be Stuck on Heating Plate
- Auto Release Feature Available

Specifications

Model	Heating Plate Size	Power	Net Weight	Gross Weight
YH-280	380mm x 280mm or 15" x 11"	1.75KW	26kg or 57"	35kg or 77"
YH-280A	280mm x 380mm or 11" x 15"	1.75KW	26kg or 57"	35kg or 77"
YH-380	380mm x 380mm or 15" x 15"	2.2KW	30kg or 66"	38kg or 84"
YH-406	406mm x 508mm or 16" x 20"	2.5KW	45kg or 99"	54kg or 122"
YH-406A	406mm x 508mm or 16" x 20"	2.5KW	45kg or 99"	54kg or 122"



Heat Press – Double Plate



Features

- Double Plates Design to Save Working Time
- Perfect in Transferring T-shirt, Socks, Garment, Blanket, Etc
- Power Saving, Accuracy and Flexibility
- Distributing Heat evenly by Advanced Heating Component
- Single Chip Processor, LCD Display, PID counting Device and PWM Output Design
- Integrated Electrical Control System
- Substrate Would not be Stuck on Heating Plate
- Convenient Adjustment and Maintenance

Specifications

Model	Heating Plate Size	Power	Remark	Gross Weight
YH-150-2TH	150mm x 200mm or 6" x 8"	0.5KW	Manual	25kg or 55"
YH-200-2TH	200mm x 300mm or 8" x 12"	1.75KW	Manual	29.5kg or 65"
YH-300-2TH	300mm x 380mm or 12" x 15"	1.75KW	Manual	53kg or 117"
YH-380-QTH	380mm x 380mm or 15" x 15"	2.2KW	Pneumatic	TBC
YH-500-QTH	500mm x 400mm or 20" x 16"	2.5KW	Pneumatic	TBC
YH-650-QTH	650mm x 500mm or 26" x 20"	3KW	Pneumatic	TBC

Eastsign

Heat Press – Mug



Features

- It is Perfect for Transferring on Mug. Vivid Color, Even Heating, Easy to Operate and High Productivity are the Characteristics.

Specifications

Model	Heating Plate Size	Heating Power	Net Weight	Gross Weight
YH-80TB	Φ 80mm x 90mm or 3.1" x 3.55"	280W	7.5kg or 17"	9.5kg or 21"
YH-80TBA	Φ 80mm x 90mm or 3.1" x 3.55"	280W	8.4kg or 18.5"	9.3kg or 20.5"
YH-80TBB	Φ 80mm x 90mm or 3.1" x 3.55"	280W	TBC	TBC

Heat Press – Plate



Features

- YH-100TP is Perfect for Transfer on Plates: Vivid Color, Even Heating, Easy to Operate and High Productivity.

Specifications

Model	Heating Plate Size	Heating Power	Remark	Net Weight	Gross Weight	Packing Size
YH-100TP	Φ 100mm or 4"	2.2KW	Manual	11.5kg or 25"	12.6kg or 28"	400mm x 280mm x 540mm 16" x 11" x 21"

Heat Press – Cup



Features

- Multi-functional Heat Pressing Machine Reduces Great Deal of Capital Investment by Combining four Applications: Garment, Mug, Cap and Plate Together.

Specifications

Model	Heating Plate Size	Heating Power	Net Weight	Gross Weight
YH-100TM	150mm x 60mm or 6" x 2.3"	1.75KW	18kg or 40"	23kg or 51"
YH-100QTM	150mm x 60mm or 6" x 2.3"	1.75KW	18kg or 40"	23kg or 51"
YH-115TM	170mm x 80mm or 7.1" x 3.1"	2.2KW	11.5kg or 25"	13.4kg or 30"

Eastsign

Laser Cutter – Edge Tracking

ET Series

- ★ Sportswear / Uniform / Fashion
- ★ Flexible fabric
- ★ Acrylic , wood

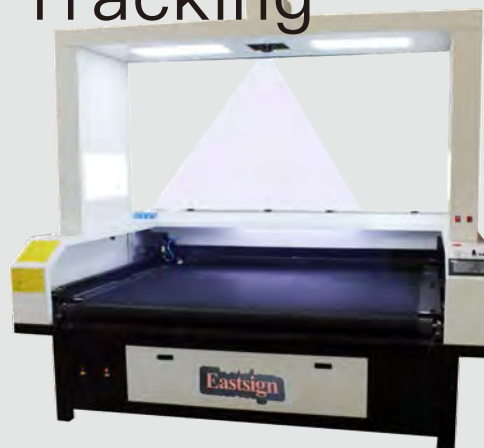

Features

- Cut Any Kind of Complex Shapes
- Fast Cutting on Demand which Keeps Low Stock Level
- Precise Cutting – Much Better than Shears and Blades
- Prevent Fraying after Cutting – High Temperature Coagulates Edge of Textile

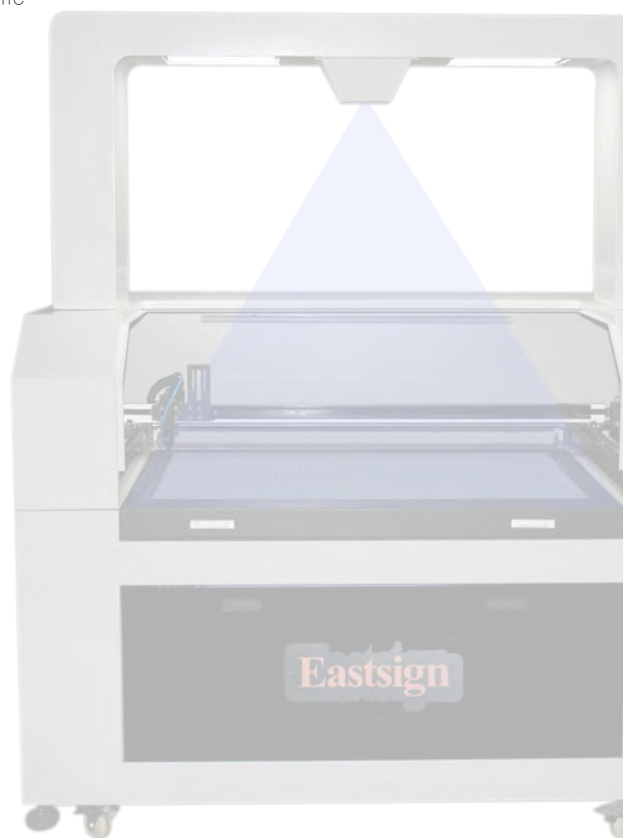

Specifications

CCD Resolution: 24 Megapixel
 Laser Type: Hermetic and Detached Chinese CO2 Laser Tube
 Motor: Domestic Stepper Motor
 Voltage: 220V, Single Phase
 Cutting Accuracy: <=0.01mm
 Cutting Speed: 8–48m per minute
 Auxiliaries: Wind Pump, Wind Pipe, Water Cooler, Data Cable, CD-ROM
 Software: Professional Cutting Software
 Cooling: Water Cooling
 Data Format: AI, BMP, PLT, DXF, DST

Model	ET-1610-R	ET-1810-R	ET-1814-R	ET-1913-R	ET-1210-H/R
Working Platform	Rolling	Rolling	Rolling	Rolling	Honeycomb/Rolling
Laser Power	130W	130W	130W	130W	80W
Power	3000W	3000W	3500W	3500W	2000W
Cutting Area	1.600m x 1.000m 63" x 39"	1.800m x 1.000m 71" x 39"	1.800m x 1.400m 71" x 55"	1.900m x 1.300m 75" x 51"	1.200m x 1.000m 47" x 39"
Machine Size (Length x Width x Height)	2.25m x 1.90m x 2.70m 89" x 75" x 106"	2.50m x 1.90m x 2.70m 98" x 75" x 106"	2.50m x 2.14m x 2.70m 98" x 84" x 106"	2.52m x 2.16m x 2.70m 98" x 85" x 106"	1.80m x 1.55m x 2.10m 71" x 61" x 83"
Packing Size	2.37m x 2.02m x 1.34m 89" x 79" x 53"	2.62m x 2.02m x 1.34m 103" x 79" x 53"	2.62m x 2.28m x 1.34m 103" x 90" x 53"	2.62m x 2.28m x 1.34m 103" x 90" x 53"	1.92m x 1.90m x 1.44m 76" x 75" x 57"
Lightbox Packing Size	2.50m x 0.4m x 0.85m 89" x 16" x 33"	2.50m x 0.4m x 0.85m 98" x 16" x 33"	2.57m x 0.4m x 0.85m 101" x 16" x 33"	2.57m x 0.4m x 0.85m 101" x 16" x 33"	
Net Weight	700kg or 1540lb	750kg or 1650lb	880kg or 1936lb	900kg or 1980lb	400kg or 880lb
Gross Weight	780kg or 1716lb	800kg or 1760lb	980kg or 2156lb	1000kg or 2200lb	450kg or 990lb

◆ Other parts are eligible for 15 months warranty under proper use (starting from the time of ex factory)

Eastsign

Laser Cutter – Mark Point

MP Series

- ★ Sportwear / Uniform / Fashion
- ★ Flexible fabric
- ★ Acrylic , wood

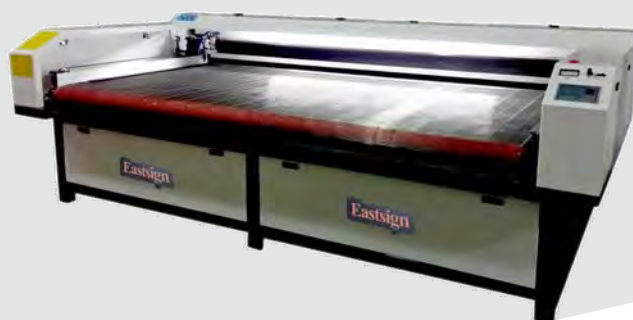

Features

- Mark Point is Ideal for Cutting Eyelash Lace
- Cut Any Kind of Complex Shapes
- Fast Cutting on Demand which Keeps Low Stock Level
- Precise Cutting – Much Better than Shears and Blades
- Large Format Cutting – Maximum size: 3.2m x 3.0m or 126" x 118"
- Prevent Fraying after Cutting – High Temperature Coagulates Edge of Textile



Specifications

Working Platform:Rolling
 CCD Resolution:3 Megapixel
 Motor:Servo-stepper
 Voltage:220V, Single Phase
 Cutting Accuracy:<=0.01mm
 Cutting Speed:10–50m per minute
 Auxiliaries:Wind Pump, Wind Pipe, Water Cooler, Data Cable, CD-ROM
 Software:Professional Cutting Software
 Cooling:Water Cooling
 Data Format:AI, BMP, PLT, DXF, DST
 Laser Type:Hermetic and Detached Chinese CO2 Laser Tube

Model	MP-1610	MP-1810	MP-2610	MP-3210
Laser Power	130W	130W	150W	150W
Power	3000W	3000W	3500W	3500W
Cutting Area	1.600m x 1.000m 63" x 39"	1.800m x 1.000m 71" x 39"	2.600m x 1.000m 102" x 39"	3.200m x 1.000m 126" x 39"
Machine Size (Length x Width x Height)	2.25m x 1.90m X 1.10m 89" x 75" x 43"	2.50m x 1.90m x 1.10m 98" x 75" x 43"	3.30m x 1.90m x 1.10m 130" x 75" x 43"	3.90m x 1.90m x 1.10m 154" x 75" x 43"
Packing Size	2.37m x 2.02m x 1.34m 93" x 79" x 53"	2.62m x 2.02m x 1.34m 103" x 79" x 53"	3.42m x 2.02m x 1.34m 135" x 79" x 53"	4.02m x 2.02m x 1.34m 158" x 79" x 53"
Net Weight	650kg or 1430lb	680kg or 1496lb	850kg or 1870lb	900kg or 1980lb
Gross Weight	680kg or 1496lb	720kg or 1584lb	900kg or 1980lb	950kg or 2090lb

◆Other parts are eligible for 15 months warranty under proper use(starting from the time of ex factory)

Eastsign

Laminator – Professional Level

Features

- Four guidepost used to make sure the stability during lifting process
- Mechanical strength is improved with Integrative structure of the bearing block
- The running resistance is reduced with the design of hinged joint on the two ends of the arm;
- Bearing on two ends of the arm to reduce the wearing, improving the durability of the machine
- Large crank with gear box to improve the application efficiency
- Positive stop added on the crank to ensure good protection of the whole lifting mechanism

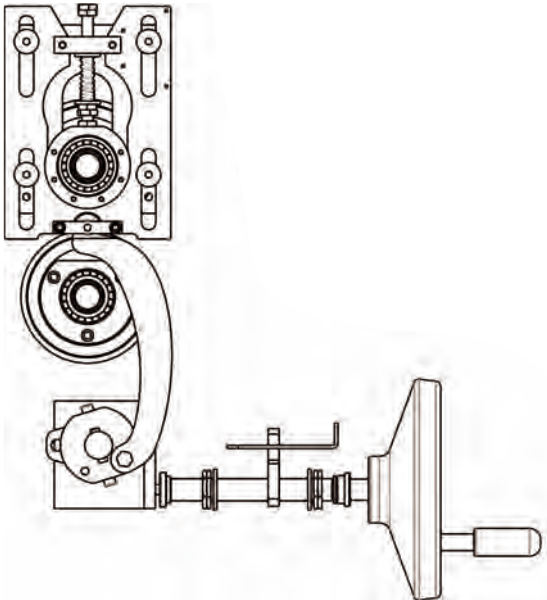

Slitter (Optional)





Photo Eye



Control Panel

Specifications

 Model	P.THERMAL
Working Width	54", 60" & 64"
Laminating Speed	0–15m/min or 0–50 ft/min
Nip Opening	35mm or 1.4"
Max. Laminating Temp	120°C or 248°F, Dual Heat
Motor Power	200W
Power Supply	220–240V AC 50Hz / 110V AC 60 Hz
Roller Diameter	102mm or 4.01"
Machine Size – 54"	1850mm x 620mm x 1330mm 73" x 25" x 53"
Machine Weight – 54"	230 kgs or 507 lbs
 Model	P.HOT
Working Width	54", 60" & 64"
Laminating Speed	0–15m/min or 0–50 ft/min
Nip Opening	35mm or 1.4"
Max. Laminating Temp	120°C or 248°F, Top Heat
Motor Power	200W
Power Supply	220–240V AC 50Hz / 110V AC 60 Hz
Roller Diameter	102mm or 4.01"
Machine Size – 60"	2050mm x 620mm x 1330mm 80" x 25" x 53"
Machine Weight – 60"	260 kgs or 573 lbs
 Model	P.WARM
Working Width	54", 60" & 64"
Laminating Speed	0–15m/min or 0–50 ft/min
Nip Opening	35mm or 1.4"
Max. Laminating Temp	40°C or 140°F, Top Heat
Motor Power	200W
Power Supply	220–240V AC 50Hz / 110V AC 60 Hz
Roller Diameter	102mm or 4.01"
Machine Size – 64"	2150mm x 620mm x 1330mm 84" x 25" x 53"
Machine Weight – 64"	275 kgs or 606 lbs

Eastsign

Laminator – Advanced Level

Features

- Membrane control panel
- Separate packing of stand
- Nip opening by hand crank
- Tooled side cover to ensure the alignment of shafts and rollers.
- Heat Assist is Available

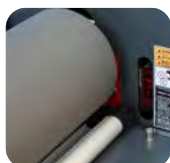
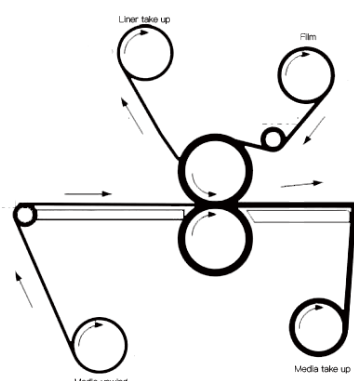

Photo Eye



Control Panel



BU-1600E.WARM
40°C or 140°F



BU-1600E.COLD
Cold only

Specifications

Model	BU-1600E.WARM/BU-1600E.COLD	
Working Width	1600mm or 63"	
Laminating speed	0-6m or 0-20' per minute	
Nip opening	35mm or 1.4"	
Motor Power	90W	
Power Supply	220-240V AC 50Hz / 110V AC 60Hz	
Roller Diameter	120mm or 4.72"	
Machine Size	1925mm x 587mm x 1385mm 76" x 24" x 55"	
Packing Size – Wooden Crate	2200mm x 630mm x 710mm 87" x 25" x 28"	
Packing Size – Carton Box	-	
Driven by	Electric	
Roller Lifting	Hand Crank	
Media Rewind	Yes	
Cold Lamination Film Unwind	Yes, Mounted on Machine Body	
Liner Rewind	Yes, Mounted on Machine Body	
Roller Pressure	Hand Crank	
Machine Weight	215kg or 474lb	220kg or 485lb
Gross Weight	245kg or 540lb	250kg or 552lb



Eastsign

Laminator – Entry Level

Features

- Most Simple Cold Laminators II Series
- Bottom Control Panel is Adopted
- Stand is Dismantled before Shipping.
Smaller Shipping Size Reduces Shipping Cost
- Nip Opening is Controlled by Hand Crank
- Heat Assist is Available

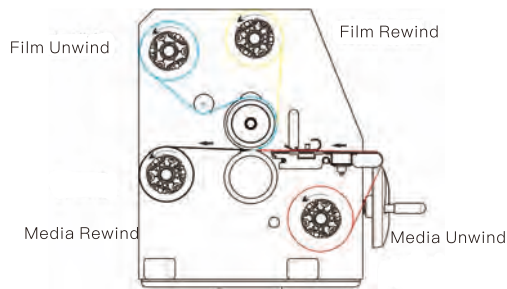

Specifications

Model	BU-1600B.WARM
Working Width	1600mm or 63"
Laminating speed	0-18 fpm (max/6mpm)
Nip opening	35mm or 1.5"
Laminating temperature	Up to 86°F(30°C) Unadjustable
Motor Power	60W
Power Supply	110V, 60Hz, 10A Single phase, 220V/240V, 15A Single Phase
Roller Diameter	102mm
Machine Size	2040mm X 610mm X 1250mm 80.3" X 24" X 49.2"
Heater	Metal cal rod
Gross Weight	TBD
Driven by	Electric
Roller Lifting	Hand Crank
Media Rewind	Yes
Heated Roller	Top heat assist
Liner Rewind	Yes, Mounted on Machine Body
Media Unwind	Yes, Mounted on Machine Body
Roller Pressure	Hand Crank



Eastsign

Laminator – Liquid

Features

- This range is applicable for adding protective coating on almost all kinds of media such as PVC banner and wallpaper.
- Solvent based or aqueous laminates are available. the purpose is to increase the outdoor durability of the inks as well as preventing the image to be scratched.
- Different mayer bar sizes are available for different laminating thicknesses.

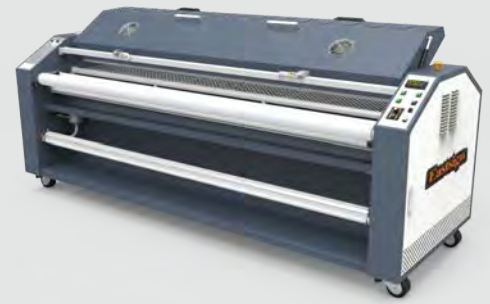
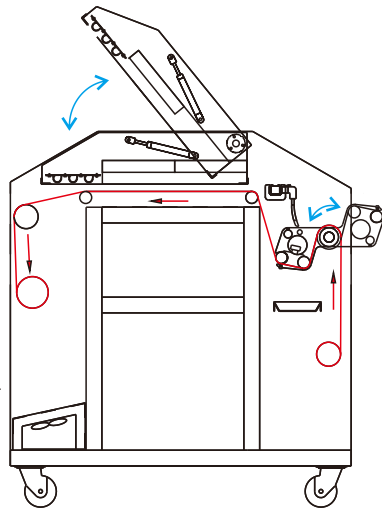

BU-1600WL
Working Width:1580mm or 62"



BU-2200WL
Working Width:2140mm or 84"

Specifications

Model	BU-1600WL	BU-2200WL	BU-3300WL
Laminating speed	1.5m/min		
Coating thickness	0.007-0.01mm		
Laminating temperature	0-150°C or 0-302°F		
Motor power	90W		
Heating power	6.5kW	7.5kW	13kW
Power supply	1 Phase/220V, 3 Phase/380V		
Roller diameter	-		
Media Rewind	Automatic, roll-to-roll		
Heating temperature	Up to 150°C/302°F		
Laminating thickness	Adjustable, depending on mayer bar		
Wastage	No wastage and scap		



Model	BU-1600WL	BU-2200WL	BU-3300WL
Machine size	2025mm x 930mm x 1050mm 80" x 37" x 42"	2630mm x 930mm x 1050mm 104" x 37" x 42"	3810mm x 1100mm x 1084mm 150" x 44" x 43"
Packing size	2150mm x 1100mm x 1230mm 85" x 44" x 49"	2750mm x 1100mm x 1230mm 108" x 44" x 49"	3980mm x 1330mm x 1310mm 157" x 53" x 52"
Machine Weight	390kg or 860lb	450kg or 992lb	810kg or 1780lb
Gross Weight	470kg or 1048lb	540kg or 1190lb	960kg or 2117lb

Eastsign

Pouch Laminator – Professional Level

Features

- Hot roller heating technology
- Overheat protection
- Operating memory function
- Sleep mode after stop for 15 mins
- Digital display with push button



Specifications

Model	FGK330-6R	FGK450-6R
Laminating width	≤330mm	≤450mm
Laminating thickness	≤1mm	
Laminating speed	400-2100mm/min	
Laminating temperature	51-150°C	
Control system & Roller Number	8-bit microprocessor & 6(4 for heated)	
Power supply	AC100,110,220-240V/50,60Hz	
Display system	Digital display	
Motor power	1150W	1550W
Machine size	550mmx295mmx135mm	670mmx295mmx135mm
Machine weight	17kg	20kg



6 Rollers

Pouch Laminator – Outside Heating

Features

- Only 3 minutes for warming up
- Hot and cold lamination available for different usage
- High quality, low sound motor for stable operation and extending durability



Specifications

Model	FGK110A	FGK160	FGK220	FGK260	FGK320-I	FGK450-I	FGk330
Laminating width	≤110mm	≤160mm	≤220mm	≤260mm	≤320mm	≤450mm	≤330mm
Laminating thickness	≤1mm						
Laminating speed	650 mm/min						
Laminating temperature	100 - 160°C						
Control system & Roller Number	8-bit microprocessor & 6(4 for heated)						
Power supply	AC100,110,220-240V/50,60Hz						
Display system	Digital display						
Motor power	200W	400W	500W	560W	650W	850W	650W
Machine size	210mmx170mmx135mm	340mmx200mmx100mm	400mmx200mmx100mm	440mmx200mmx100mm	500mmx200mmx100mm	630mmx200mmx100mm	500mmx200mmx100mm
Machine weight	4kg	6kg	6.5KG	7KG	8KG	9KG	7.5KG

Pouch Laminator – Dual Heat



Features

- Hot roller heating technology
- Overheat protection, cooling fans
- Adjustable temperature control for various film thickness and different materials

Specifications

Model	Width	Thickness	Speed	Power	Size	Weight
PRO-260	≤260mm	≤1mm	540mm/min	580	455 X 200 X 110mm	8kg
PRO-330	≤330mm	≤1mm	540mm/min	700	515 X 200 X 110mm	9kg
PRO-450	≤450mm	≤1mm	540mm/min	940	650 X 200 X 110mm	10kg



Eastsign

Flatbed Applicator – Professional Level

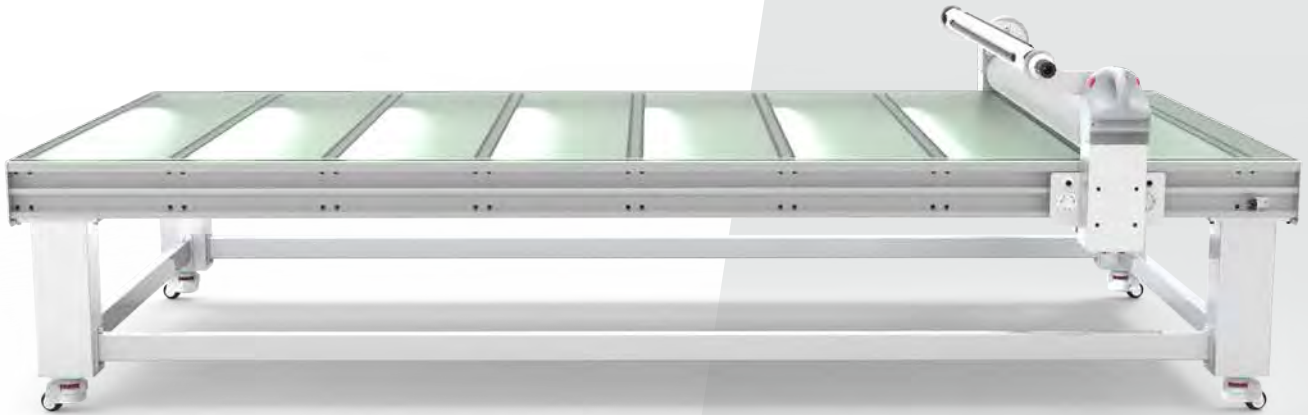

Options

- ★ Media tray
- ★ Clear PVC Cutting Mat for Top of Table



Features

- Adjustable table height
- Reduce production time dramatically
- Consistent high quality work flow
- Time savings equals more profit
- Elegant design, easy to use
- Minimal training required for operator
- Only one person required

Specifications

Variable Working Speed: Up to operator
 Max Temp: 60°C
 Max. Nip Opening: 50mm
 Heating: Infrared
 Preheating: 10~15min
 Roller Upgrade: Air Cylinder
 Roller Diameter: 130mm
 LED light: Y
 Silent air compressor: Y
 Power Input: 0.8~1.0kw/h
 Pressure Range: 0~0.8Mpa

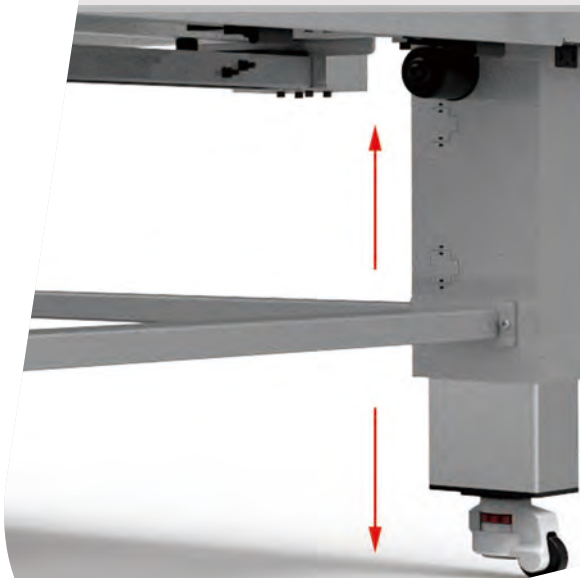

Model	FA-1325325	FA-1530530	FA-1737'37
Max. Working Width	1300mm x 2500mm 51" x 98.4"	1500mm x 3000mm 59" x 118"	1700mm x 3700mm 67" x 146"
Packing Size (Working Table)	N/A	3900mm x 2250mm x 550mm 154" x 89" x 22"	N/A
Packing Size (Air Compressor)	N/A	520mm x 520mm x 220mm 21" x 21" x 9"	N/A
Packing Size (Main Roller)	N/A	1820mm x 200mm x 250mm 72" x 9" x 10"	N/A
Weight (NW)	580kgs	800kgs	920kgs
Weight (GW)	660kgs	880kgs	1000kgs

Eastsign

Flatbed Applicator – Smart Table

Features

- PVC foam board
- Metal panel
- Glass

Laminating

- Smart table can also be used for post processing laminating in cold or heat assist modes.

Mounting

- It only takes one person to mount digital prints or adhesive stickers on to many forms of substrate. Mount on foam board, corrugated panels, metal panels, banners and glasses, all without bubbles.

Work Station

- The surface can also be used for any of your signage uses. For activities like trimming graphics, doing layouts, weeding, etc, smart table can be a great support for your shop in speeding up jobs and improving efficiency.

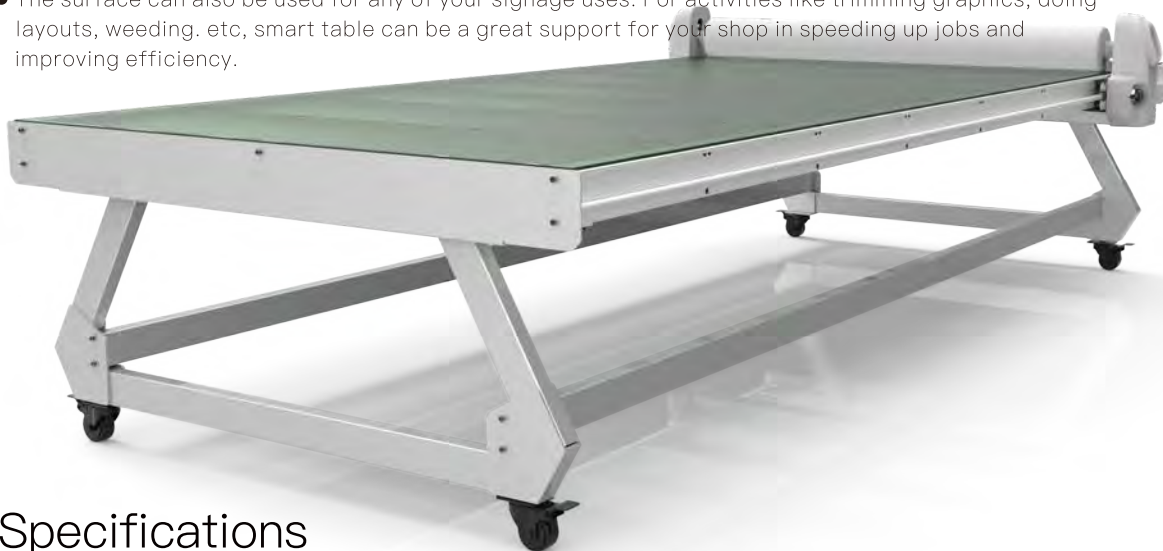

Specifications

Model	FA-1325-S	FA-1530-S
Max.Working Width	1300mm x 2500mm or 51" x 98.4"	1500mm x 3000mm or 59" x 118"
Variable Working Speed	Up to operator	Up to operator
Roller Diameter	130mm	130mm
Max. Nip Opening	50mm	50mm
Roller Upgrade	Air Cylinder	Air Cylinder
Silent air compressor	Y	Y
Power Input	0.8-1.0kw/h	0.8-1.0kw/h
Pressure Range	0-0.8Mpa	0-0.8Mpa
Packing Size (Working Table)	3100mm x 1400mm x 580mm 122" x 55" x 23"	N/A
Packing Size (Air Compressor)	520mm x 520mm x 220mm 21" x 21" x 9"	N/A
Weight (NW)	380kgs	500kgs
Weight (GW)	460kgs	580kgs

Eastsign Fabric Slitter

Features

- Fully automated design
- 3" inner shaft for RS-1820L
- Applicable Materials : Fabric / Banner / Flex / Mesh / Tarpaulin / Reflective / Sheeting / Self-adhesive Vinyl / Foam Adhesive Tape / Double-sides Adhesive Tape / Application Tape / Photo Paper

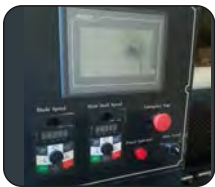

Control Panel-01



Control Panel-02



Pneumatic Seal Shaft



Cutting Blade



Specifications

Model	FS-1820L
Max Media Loading Width	1.98m or 78"
Cutting Width	200mm-1800mm or 8" -
Max Diameter of Blade	350mm or 13.8"
Max Cutting Diameter	300mm or 11.8"
Core Diameter	76.2mm or 3"
Power	7kW
Voltage	220V, Single Phase
Rotary Speed (Shaft)	720 Round per Minute
Rotary Speed (Blade)	900 Round per Minute
Air Compressor	Not Included
Machine Dimension	2980mm x 1100mm x 1250mm 118" x 44" x 49"
Packing Size	3380mm x 1500mm x 1650mm 133" x 59" x 65"

Eastsign

Roll Slitter

Features

- Material to be fastened by air expanding system
- User-friendly LCD control panel
- 2" & 3" interchangeable shaft for RS-1800R
- Position of blade can be set manually or automatically
- Applicable materials: Banner/Flex/Mesh/Tarpaulin/Reflective/Sheeting/Self-Adhesive Vinyl/Foam Adhesive Tape/Double-sides Adhesive Tape/Application Tape/Photo Paper



Control Panel



Air Expanding Shaft

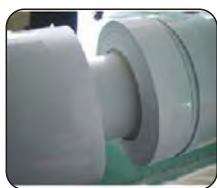

Cutting result



Holder



Specifications

Max Loading Weight: 400kg or 880lb
 Max Diameter of Blade: 300mm or 11.8"
 Max Cutting Diameter: 250mm or 10"
 Max Diameter of Media on Rewinding Shaft: 350mm or 13.8"
 Motor power: 0.75kW
 Voltage: AC 110/220V, 50/60Hz
 Rotary speed: 200 Round per Minute
 Width Cutting Tolerance: 1mm
 Air Compressor / Rewinding Shaft: Optional

Model	RS-1800R	RS-3300R
Max Media Loading Width	2000mm or 78"	3300mm or 130"
Cutting Width	230mm – 1730mm or 9" – 68"	230mm – 3050mm or 9" – 120"
Core Diameter	76.2mm or 3" / 50.8mm or 2"	76.2mm or 3"
Weight	350kg or 772lb	480kg or 1058lb
Machine size(mm)(L x W x H)	2600mm x 1000mm x 1300mm (101"x40"x51")	4000mm x 1000mm x 1300mm (158"x40"x51")
Packing size(mm)(L x W x H)	2700mm x 700mm x 1400mm (106"x28"x55")	4300mm x 700mm x 1400mm (170"x28"x55")

Eastsign

5m Slitter

Features

- Good for cutting flex vinyl, mesh, white solvent vinyl, one way vision, self-adhesive vinyl, reflective sheeting, reflective sheeting, application tape, foam adhesive tape, double-sides adhesive tape, etc.
- With the function of digital display for rewind & unwind, also with the semi-automatic cutting width control, customer may rewind or unwind film roll according to the required length.

Specifications

Model	FQ-1600L	FQ-1600S
Rated Voltage	220V	220V
Rated Power	1600W	1600W
Speed	0~300rpm	0~300rpm
Maximum Cutting	5100mm	3200mm
Shape Size	5900 x850 x1000 mm	4100x850 x1000 mm
Pack Size	Main Body:6120x660x620mm Cutter Part:650x575x500mm	Main Body:4130x670x670mm Cutter Part:650x575x500mm
Maximum Diameter	Φ280mm	Φ280mm
Rewind	Yes	Yes
Horizontal Cut	Yes	Yes
Weight	475kg	385kg

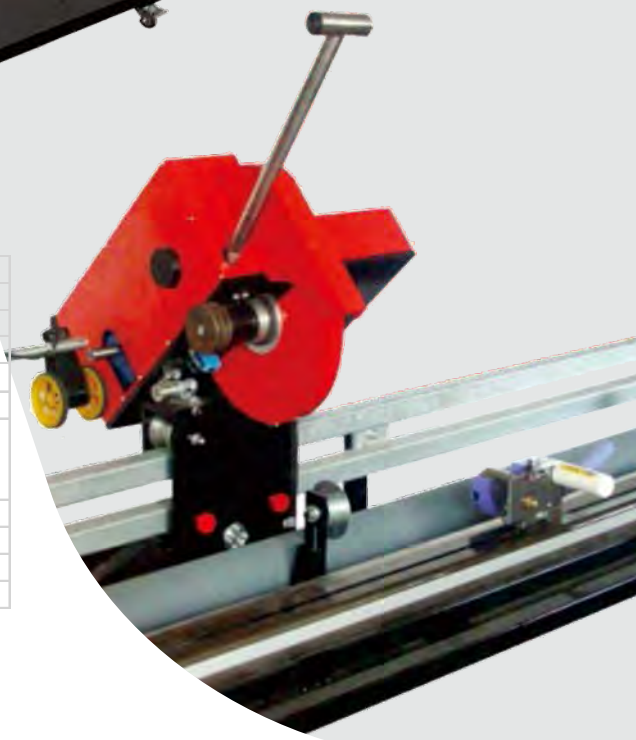

Table Slitter

Features

- Expanding shaft fixes roll materials on the shaft firmly, which avoids damage of material.
- 2" or 3" shaft is available.
- Banner/ Flex /Self-adhesive Vinyl / Adhesive tape / Reflective sheeting can be cut by table slitter.



Model	Dimension (L x W x H)	Weight	Max cutting width	Max diameter of blade	Max cutting diameter	Core diameter	Power supply	Rotary speed
TS-1520	2330 x 560 x 600mm (92" x 22" x 24")	185kg (408lb)	1520mm (60")	250mm (10")	200mm (8")	76.2mm(3")/ 50.8mm(2")	0.75KW,AC110/ 220V,50/60Hz	140 rpm

Eastsign

UV Coater

UVC-48

- ★ Posters
- ★ POP Displays
- ★ Flexible Substrate
- ★ Rigid Substrate



Front



Back



Left



Right



Features

- Wide range of coating thicknesses: 0.003mm–0.35mm or 0.12mil–14mil
- Coating speed: up to 20m or 65' per minute
- Suitable for PVC Banner/Vinyl, PVC Foam, PS Foam, PP Hollow, Acrylic, Aluminium Composite Panel, Tiles and Glass
- Protective layer for Mold, Acid, Abrasion, Chemicals, UV Radiation or Graffiti
- Adding color on Clear Acrylic, PP sheet or Glass

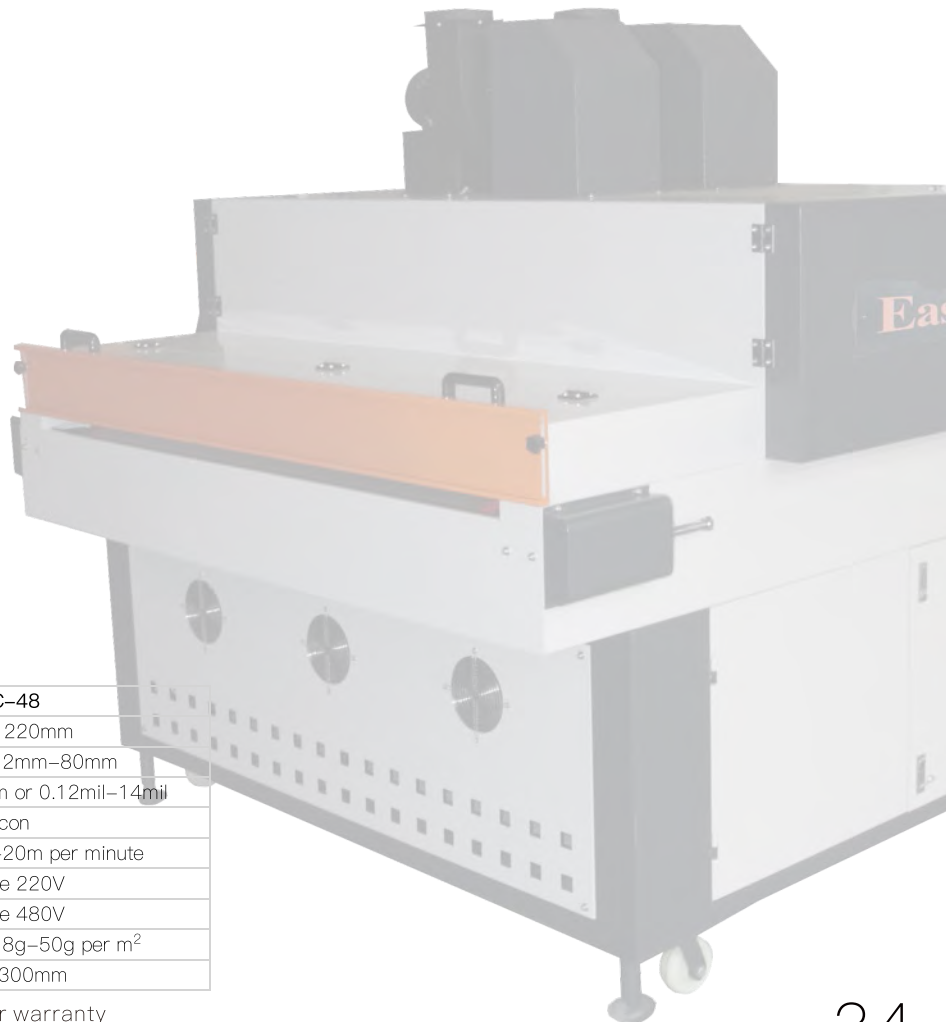

Specifications

Model	UVC-48
Max. Coat Width	48" or 1220mm
Substrate Thickness	0.1"–3.1" or 2mm–80mm
Coating Thickness	0.003mm–0.35mm or 0.12mil–14mil
Coating Roller	Silicon
Coater/Dryer Speed	16'–65' or 5m–20m per minute
Voltage (Coater)	3 Phase 220V
Voltage (Curing Unit)	3 Phase 480V
Coating Consumption	0.3oz–1.8oz or 8g–50g per m ²
Minimum Coating Length	12" or 300mm

◆ Coating Roller and Curing UV Lamp is not under warranty

Eastsign

Eyelet Machine / Dies



Die



Grommet: 3mm-15mm

Features

- Economical and durable
- Inter-changeable dies and grommets
- Easy to operate
- Suitable for banner, canvas, flag textile etc.

Specifications

Model	GR30M	GR80M
Weight	9kg(19.8lb)	6.5kg(14.3lb)
Inner diameter of grommet	Φ3mm-Φ15mm	Φ3mm-Φ15mm



GR30M
Manual machine



GR80M
Manual machine

Movable Auto Grommet Machine



ST-135

Features

- Smart and quick with automatic grommet loading systems
- Can be fixed on table or moving on ground to work on straight line guided by laser
- Automatic Grommet funnel stops when the grommet track is full
- Suitable for banner, canvas, flag, textile etc.

Specifications

Model	ST-105	ST-135
Dimension(LxWxH)	680mmx398mmx920mm	680mmx398mmx920mm
Weight	40kg/88lb	41kg/90lb
Diameter of grommet	10.5mm	13.5mm
Type of washer/eyelet	Plastic/Metal	Plastic/Metal or Metal/Metal
Power	2kw(punching)	2kw(punching)
Power supply	110/220v,50/60Hz	110/220v,50/60Hz
Working efficiently	1200pcs/hour	1200pcs/hour

Eastsign Welding Machine

Features

- Total seaming solutions for all PVC materials, especially for TarPaulin and banner
- Welding length: up to 30m
- Welding width: varies by changing welding heads
- High welding speed with low consumption
- Tape welding available



Specifications

 Model	ZL-3000S
Voltage	110V/220V, 50Hz/60Hz
Power	3kW
Surging Frequency	27.12MHz ± 0.5%
Welding Pressure	4-6kg/cm ²
Welding Speed	2-6m/min
Welding Thickness	3mm (Multi-layer)
Welding Width	20mm or 0.79"/30mm or 1.18"/40mm or 1.57"
Table Length	6m or 19.7' (up to 30m or 98.4')



Ammeter Infrared Guidance



Sample

Welding Tape

Hot Air Welder



Welding gun



Features

- Economical Step Motor Sub-division System
- Easily Adjustable with Good Heat Dispersion
- Compatible with CorelDraw, CAD or Other Design Software and Output Directly
- Long Working Life, Low Noise, Stable System, Lower Price

Specifications

 Model	6001B
Voltage	220V ± 10%, 50Hz
Power	2kW
Speed	1m-6m / minute or 3.3' - 19.7' / minute
Weight	15kg or 33lb
Packing Size	450mm x 450mm x 500mm 18" x 18" x 20"
Welding Thickness	1mm - 5mm or 79 mil to (Multi-layer)

Eastsign Cutting Plotter

Features

- Cutting speed: up to 1000mm (39") per second, media feeding speed: up to 2020mm (46") per second
- Mechanical resolution (DSP): up to 0.0191mm/step (0.00073"), repeating resolution: up to 0.127MM (0.00049")
- Cutting force: up to 800 gram
- Available for media thickness: up to 0.8mm (0.0315")
- Transmission interface by USB and U.Flash
- Compatible with Adobe Illustrator, CorelDRAW and FlexiSign



Specifications

Cutting Force: 10~800g

Memory: 512KB, available to be extended to 8MB

Commands Set: DM/PL/HPGL

Power Supply: AC160V~240V 50~60HZ

Item	A24	A30	A40	A48
Max. Paper Width	720mm	850mm	1100mm	1350mm
Max. Cutting Width	630mm	750mm	1000mm	1250mm
Max Cutting Speed	Whole cutting: 1000mm/s, Y axis max cutting: 2020mm/s			
Packing Size	1120*386*330mm	1250*386*330mm	1550*386*330mm	1750*386*330mm
G.W	26KG	29KG	32KG	36KG

Eastsign

Electrical Trimmer



Features

- Suitable for most kinds of rigid substrate & all kinds of flexible substrate for advertisement application
- Replaceable trimming heads, specially designed for different materials, best trimming/cutting results guaranteed
- State-of-the-art technology with advanced manufacturing equipment to ensure the quality of the trimmer
- European CE/BV certified



Model	Max Cutting width	Max Cutting thickness	Laser points line	Power input	Volt	N.W.
ET-1600	1600mm	6mm	Available	0.8-1.0kw/h	110/220v	90kgs
ET-2500	2500mm	6mm	Available	0.8-1.0kw/h	110/220v	130kgs

Manual Trimmer

Features

- Application material include engineering drawing, photo paper, etc.
- Blade depth adjustable
- Protective cover
- Stand holder optional
- Trapezoid blade



Model	Available width	Working Depth	Working Pattern
MT-01	1600mm/64"	0-12mm	By hand
MT-02	2600mm/104"	0-12mm	By hand

Eastsign

Tension Fabric Display



ZL27A-S33/43/63
8FT/10FT/20FT



ZL27B-C33/43/63
8FT/10FT/20FT



ZL27C-W43/63
10FT/20FT



ZL27D-U33/43
8FT/10FT

Features

- Solid frames for dye-sub textile prints, canvas, polyester or banner
- Available in Flat, Curve or Wave with spot light
- Easy installation

Model: ZL27A

Color: Silver/Straight

Materials: Aluminum

Packing: Carton box

Model	Shape	Size (mm)
ZL27A-S33	Straight	8FT 2440 x 2230
ZL27A-S43	Straight	10FT 2920 x 2230
ZL27A-S63	Straight	20FT 5940 x 2230



ZL27A-S33/S43/S63



ZL27B-C33/C43/C63

Model: ZL27B

Color: Silver/Curved

Materials: Aluminum with LED

Packing: Carton box

Model	Shape	Size (mm)
ZL27B-C33	Curve	8FT 2440 x 2230
ZL27B-C43	Curve	10FT 2920 x 2230
ZL27B-C63	Curve	20FT 5940 x 2230



ZL27C-W43/W63

Model: ZL27C

Color: Silver/Wave shape

Materials: Aluminum

Packing: Carton box

Model	Shape	Size (mm)
ZL27C-W43	Wave	10FT 2920 x 2230
ZL27C-W63	Wave	20FT 5940 x 2230



ZL27D-U33/U43

Model: ZL27D

Color: Silver/U shape

Materials: Aluminum

Packing: Carton box

Model	Shape	Size (mm)
ZL27D-U33	Curve	8FT 2440 x 2230
ZL27D-U43	Curve	10FT 2920 x 2230

Eastsign

Snake Stand

Model: ZL29-1

Color: Silver

Materials: Aluminum

Packing: Carton box

Model	Shape	Size (mm)
ZL29-1	Snake S1	940 x 2100



ZL29-1

Model: ZL29-2

Color: Silver

Materials: Aluminum

Packing: Carton box

Model	Shape	Size (mm)
ZL29-2	Snake S2	940 x 2100

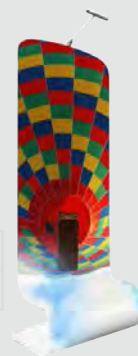

ZL29-2



ZL29-3

Model: ZL29-3

Color: Silver

Materials: Aluminum

Packing: Carton box

Model	Shape	Size (mm)
ZL29-3	Snake S3	940 x 2100



ZL29-4

Model: ZL29-4

Color: Silver

Materials: Aluminum

Packing: Carton box

Model	Shape	Size (mm)
ZL29-4	Snake S4	940 x 2100



ZL29-5

Model: ZL29-5

Color: Silver

Materials: Aluminum

Packing: Carton box

Model	Shape	Size (mm)
ZL29-5	T Stand	850 x 2000



Eastsign

Snake Stand

Model: ZL29-6

Color: Silver

Materials: Aluminum

Packing: Carton box

Model	Shape	Size (mm)
ZL29-6	U1 Stand	800 x 2000



ZL29-6

Model: ZL29-8

Color: Silver

Materials: Aluminum

Packing: Carton box

Model	Shape	Size (mm)
ZL29-8	U3 Stand Economic	800 x 2000



ZL29-8

Model: ZL29-L1

Color: Silver

Materials: Aluminum

Packing: Carton box

Model	Shape	Size (mm)
ZL29-L1	L1 Stand	380 x 1300



ZL29-L1

Model: ZL29-L2

Color: Silver

Materials: Aluminum

Packing: Carton box

Model	Shape	Size (mm)
ZL29-L2	L2 Stand	380 x 1300



ZL29-L2

Model: ZL29-TC1

Color: Silver

Materials: Aluminum

Packing: Carton box

Model	Shape	Size (mm)
ZL29-S-TC1	C1 Stand	3000 x 2280/1220



ZL29-TC1

Eastsign

Snake Stand

Model: ZL29-ST

Color: Silver

Materials: Aluminum

Packing: Carton box

Model	Shape	Size (mm)
ZL29-ST	Tree Stand	850 x 1800



ZL29-ST

Model: ZL29-S-TC2

Color: Silver

Materials: Aluminum

Packing: Carton box

Model	Shape	Size (mm)
ZL29-S-TC2	C2 Stand	3000 x 2280



ZL29-S-TC2



ZL29-AS

Model: ZL29-AS

Color: Silver

Materials: Aluminum

Packing: Carton box

Model	Shape	Size (mm)
ZL29-AS	Square Arch	2440 x 1000 x 2230

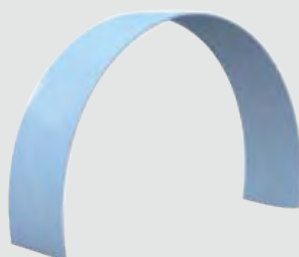

ZL29-AR

Model: ZL29-AR

Color: Silver

Materials: Aluminum

Packing: Carton box

Model	Shape	Size (mm)
ZL29-AR	Round Arch	6000 x 1000 x 4000

Eastsign

Counters and Kiosks

Features

- Solid frames for dye-sub textile prints, canvas, polyester or banner
- Available in Flat, Curve or Wave with spot light
- Easy installation

Model: ZL28-CO

Color: Silver
Materials: Aluminum
Packing: Carton box

Model	Shape	Size (mm)
ZL28-CO	Oval	600 x 390 x 1000



ZL28-CO

Model: ZL28-CT

Color: Silver
Materials: Aluminum
Packing: Carton box

Model	Shape	Size (mm)
ZL28-CT	Troangle	600 x 600 x 1000



ZL28-CT



ZL28-CR

Model: ZL28-CR

Color: Silver
Materials: Aluminum
Packing: Carton box

Model	Shape	Size (mm)
ZL28-CR	Rectanglar	800 x 550 x 1000



ZL28-CD

Model: ZL28-CD

Color: Silver
Materials: Aluminum
Packing: Carton box

Model	Shape	Size (mm)
ZL28-CD	Drop	920 x 450 x 1000



Eastsign

Counters and Kiosks

Features

- Solid frames for dye-sub textile prints, canvas, polyester or banner
- Available in Flat, Curve or Wave with spot light
- Easy installation

Model: ZL28-CB

Color: Silver

Materials: Aluminum

Packing: Carton box

Model	Shape	Size (mm)
ZL28-CB	Bean	900 x 450 x 1000



ZL28-CB



ZL28-CRO



ZL28-CRO-T

Model: ZL28-CRO

Color: Silver

Materials: Aluminum

Packing: Carton box

Model	Shape	Size (mm)
ZL28-CRO	Round	φ600 x 1000

Model: ZL28-CRO-T

Color: Silver

Materials: Aluminum

Packing: Carton box

Model	Shape	Size (mm)
ZL28-CRO-T	Tapered Round	φ700/500 x 1000

Overhead Hanging Signs



ZL30-1



ZL30-2



ZL30-3



ZL30-4



ZL30-5



ZL30-6



Model: ZL30-ALL

Color: Silver

Materials: Aluminum

Packing: Carton box

Model	Shape	Size (mm)
ZL30-1	Triangle	3050 x 1060
ZL30-2	Square	2440x2440 x 1060
ZL30-3	Circle	φ3050 x 1060
ZL30-4	Tapered Circle	φ3050/2440 x 1060
ZL30-5	Pinwheel	3050 x 1060
ZL30-6	Vertical Single Round	1830 x 1060

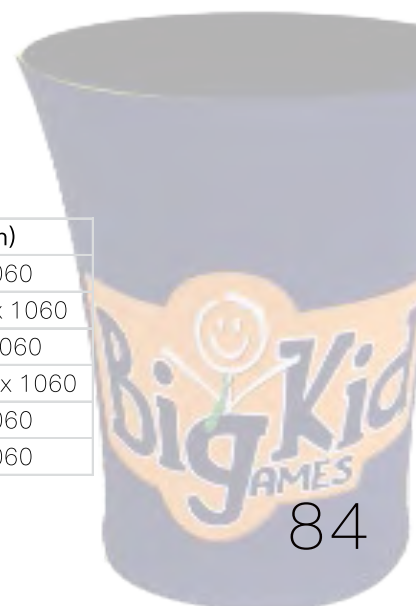

Eastsign

Trade Show Display Packages

Model: Booth63-1

Application: standard
Materials: Aluminum Frame
Packing: Carton box

Model	Size (mm)
Booth63-1	6000 x 3000



Booth63-1

Model: Booth63-2

Application: standard
Materials: Aluminum Frame
Packing: Carton box

Model	Size (mm)
Booth63-2	6000 x 3000



Booth63-2

Model: Booth63-3

Application: standard
Materials: Aluminum Frame
Packing: Carton box

Model	Size (mm)
Booth63-3	6000 x 3000



Booth63-3



Booth33-1

Model: Booth33-1

Application: standard
Materials: Aluminum Frame
Packing: Carton box

Model	Size (mm)
Booth33-1	3000 x 3000



Booth66-2

Model: Booth66-2

Application: standard
Materials: Aluminum Frame
Packing: Carton box

Model	Size (mm)
Booth66-2	6000 x 6000



Booth33-2

Model: Booth33-2

Application: standard
Materials: Aluminum Frame
Packing: Carton box

Model	Size (mm)
Booth33-3	3000 x 3000



Eastsign

Textile Fabric Frame & LED Light Frame



Back-lit Light

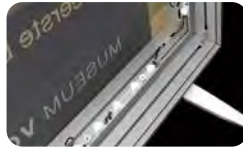

Edge-lit Light



LED Frame For Wall



For Wall

Features

- Solid frames for dye-sub textile prints, canvas, polyester or banner
- Flat & lighting effects
- All parts & aluminum profiles can be purchased separately
- Easy installation



Standing



hanging

Model: ZL26A

Color: Silver

Materials: Aluminum with LED

Packing: Carton box



ZL26-45-2



ZL26-80-2



ZL26-120-2



ZL26-120-2D

ZL26-45-2	Depth 45mm Double-sided, Standing with base
ZL26-80-2	Depth 80mm Double-sided, Standing with base,with LED light
ZL26-120-2	Depth 120mm Double-sided, Standing with base,with LED light
ZL26-120-2D	Depth 120mm Double-sided, Standing with base,with LED light

Model: ZL26B

Color: Silver

Materials: Aluminum with LED

Packing: Carton box



ZL26-17



ZL26-20



ZL26-30



ZL26-35



ZL26-40

ZL26-17	Depth 17mm Single-sided, Wall mounted
ZL26-20	Depth 20mm Single-sided, Wall mounted
ZL26-30	Depth 30mm Single-sided, Wall mounted
ZL26-35	Depth 35mm Single-sided, Wall mounted
ZL26-40	Depth 40mm Single-sided, Wall mounted



Eastsign

Textile Fabric Frame

Features

- Solid frames for dye-sub textile prints, canvas, polyester or banner
- Flat & lighting effects
- All parts & aluminum profiles can be purchased separately
- Easy installation



ZL26-100

ZL26-120



ZL26-120-1

ZL26-SR

Model: ZL26C

Color: Silver

Materials: Aluminum with LED

Packing: Carton box

ZL26-100	Depth 100mm Single-sided with Single-sided with LED light, Wall mounted, Standing with base
ZL26-120	Depth 120mm Single-sided with Single-sided with LED light, Wall mounted, Standing with base
ZL26-120-1	Depth 120mm Single-sided with Single-sided with LED light, Wall mounted, Standing with base
ZL26-SR	Suport Bar

Model: ZL26D

Color: Silver

Materials: Aluminum with LED

Packing: Carton box



ZL26-60

ZL26-60-1B

ZL26-60-1E

ZL26-80

ZL26-80-1

ZL26-60	Depth 60mm Single-sided with LED light, Wall mounted, Standing with base
ZL26-60-1B	Depth 60mm Single-sided with LED BACK-light, Wall mounted, Standing with base
ZL26-60-1E	Depth 60mm Single-sided with LED Edge-light, Wall mounted, Standing with base
ZL26-80	Depth 80mm Single-sided with LED light, Wall mounted, Standing with base
ZL26-80-1	Depth 80mm Single-sided with LED light, Wall mounted, Standing with base



ES-LB-1.2W

ES-LE05-1.5W

ES-LE05-2W



SPARE PARTS

ES-FB-BB1/2

ES-FB-BS1



ES-FB-BS2

Accessories

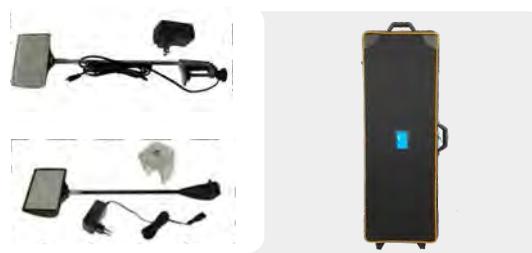

LED light
Trolley Case

Eastsign Canopy Tents

Model: ZL19-1

Color: Silver

Materials: Iron Frame

Unit/Carton: 1 pcs

Packing: Canvas bag/Trolley bag

- Heavy duty
- Easy to set up
- Graphic printing is available

Model	Dimension	Packing Size(m)	Gross Weight
ZL19-1-33	3.0m x 3.0m steel	1.62m x 0.26m x 0.26m	19kg(41.8lb)
ZL19-1-45	3.0m x 4.5m steel	1.62m x 0.26m x 0.30m	24kg(52.8lb)
ZL19-1-22	2.0m x 2.0m steel	1.62m x 0.26m x 0.26m	17kg(37.4lb)
ZL19-1-23	2.0m x 3.0m steel	1.62m x 0.26m x 0.26m	19kg(41.8lb)
ZL19-1-36	3.0m x 6.0m steel	1.62m x 0.26m x 0.34m	32kg(70.4lb)



3 x 3/2 x 2



3 X 4.5



3 X 6

Model: ZL19-2

Color: Silver

Materials: Aluminum Frame

Unit/Carton: 1 pcs

Packing: Canvas bag/Trolley bag

- Heavy duty
- Easy to set up
- Graphic printing is available

Model	Dimension	Packing Size(m)	Gross Weight
ZL19-2-33	3.0m x 3.0m Aluminum	1.68m x 0.26m x 0.26m	17kg(37.4lb)
ZL19-2-45	3.0m x 4.5m Aluminum	1.68m x 0.26m x 0.30m	19kg(41.8lb)
ZL19-2-22	2.0m x 2.0m Aluminum	1.58m x 0.26m x 0.26m	15kg(33lb)
ZL19-2-23	2.0m x 3.0m Aluminum	1.68m x 0.26m x 0.26m	17kg(37.4lb)
ZL19-2-36	3.0m x 6.0m Aluminum	1.68m x 0.26m x 0.34m	25kg(55lb)

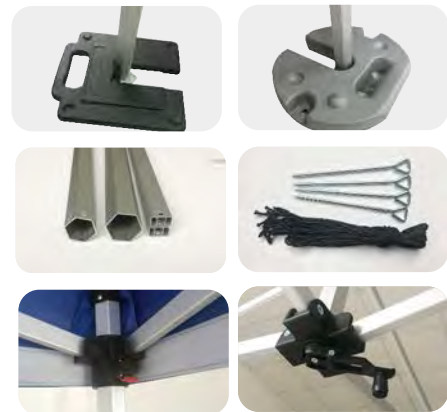

ZL19-2

Eastsign Banner Stands

Model: ZL1-10A(Single-sided)

Color: Silver

Materials: Aluminum

Packing: Canvas bag

- Autoshape stand base with luxury design
- Retrieve picture easily

Model	Dimension(W*H)	Packing Size(m)	Gross Weight	Unit/Carton
ZL1-10A	0.80m x 2.00m	0.89m x 0.27m x 0.54m	19.0kg(41.8lb)	4
ZL1-10A	0.85m x 2.00m	0.94m x 0.27m x 0.54m	19.5kg(42.2lb)	4

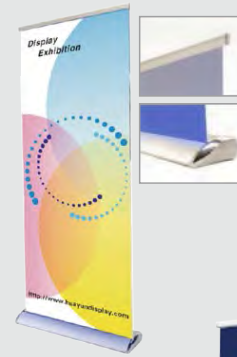

ZL1-10A



ZL1-10A-N

Model: ZL1-10A-N

Color: Silver

Materials: Aluminum

Packing: Canvas Bag

- Autoshape stand base with luxury design
- Retrieve picture easily

Model	Dimension(W*H)	Packing Size(m)	Gross Weight	Unit/Carton
ZL1-10A-N	0.80m x 2.00m	0.89m x 0.25m x 0.50m	16.0kg(35.2lb)	4
ZL1-10A-N	0.85m x 2.00m	0.94m x 0.25m x 0.50m	17.0kg(37.4lb)	4



ZL1-3



ZL1-2A

Model: ZL1-3

Color: Silver

Materials: Aluminum

Packing: Canvas Bag

- Various size available

Model	Dimension(W*H)	Packing Size(m)	Gross Weight	Unit/Carton
ZL1-3	0.60m x 2.00m	0.67m x 0.23m x 0.30m	16kg(35.2lb)	6
ZL1-3	0.80m x 2.00m	0.87m x 0.23m x 0.30m	19.0kg(41.8lb)	6
ZL1-3	0.85m x 2.00m	0.93m x 0.23m x 0.30m	19.5kg(42.9lb)	6
ZL1-3	0.90m x 2.00m	0.97m x 0.23m x 0.30m	20kg(44.0lb)	6
ZL1-3	1.00m x 2.00m	1.07m x 0.23m x 0.25m	17kg(37.4lb)	4

Model: ZL1-2A

Color: Silver

Materials: Aluminum

Packing: Canvas Bag

- Various size available

Model	Dimension(W*H)	Packing Size(m)	Gross Weight	Unit/Carton
ZL1-2A	0.60m x 2.00m	0.67m x 0.23m x 0.30m	12.5kg(27.5lb)	6
ZL1-2A	0.80m x 2.00m	0.87m x 0.23m x 0.30m	14.0kg(30.8lb)	6
ZL1-2A	0.85m x 2.00m	0.93m x 0.23m x 0.30m	14.5kg(31.9lb)	6
ZL1-2A	0.90m x 2.00m	0.97m x 0.23m x 0.30m	15.0kg(33.0lb)	6
ZL1-2A	1.00m x 2.00m	1.07m x 0.23m x 0.25m	17kg(37.4lb)	6
ZL1-2A	1.20m x 2.00m	1.27m x 0.23m x 0.25m	13kg(28.6lb)	4



ZL1-2C

Model: ZL1-2C

Color: Silver

Materials: Aluminum

Packing: Canvas Bag

- Various size available

Model	Dimension(W*H)	Packing Size(m)	Gross Weight	Unit/Carton
ZL1-2C	0.60m x 2.00m	0.67m x 0.23m x 0.30m	12.5kg(27.5lb)	6
ZL1-2C	0.80m x 2.00m	0.87m x 0.23m x 0.30m	14.0kg(30.8lb)	6
ZL1-2C	0.85m x 2.00m	0.93m x 0.23m x 0.30m	14.5kg(31.9lb)	6
ZL1-2C	0.90m x 2.00m	0.97m x 0.23m x 0.30m	15.0kg(33.0lb)	6
ZL1-2C	1.00m x 2.00m	1.07m x 0.23m x 0.25m	17kg(37.4lb)	6

Eastsign Banner Stands

Model: ZL3-C

Color: Silver

Materials: Aluminum

Packing: Canvas Bag

- Heavy duty
- Stable structure
- Ideal display for indoor usage

Model	Dimension(W*H)	Packing Size(m)	Gross Weight	Unit/Carton
ZL3-C	0.60m x 1.60m	1.05m x 0.23m x 0.27m	14.0kg(30.8lb)	10
ZL3-C	0.80m x 1.80m	1.05m x 0.23m x 0.27m	15.0kg(33.0lb)	10
ZL3-C	1.20m x 2.00m	1.35m x 0.30m x 0.27m	20.0kg(44.0lb)	10



ZL3-C

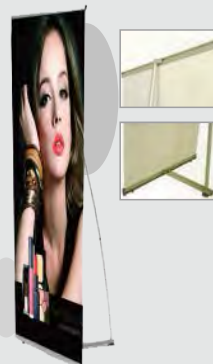

ZL4-6

Model: ZL4-6

Color: Silver

Materials: Aluminum Frame

Packing: Canvas bag with padding

- Heavy duty/Luxury packing with padding
- Excellent display for indoor purposes
- Height adjustable

Model	Dimension(W*H)	Packing Size(m)	Gross Weight	Unit/Carton
ZL4-6	0.80m x 1.80m	0.9m x 0.23m x 0.3m	19.0kg(41.8lb)	10
ZL4-6	0.85m x 2.00m	0.9m x 0.23m x 0.3m	20.0kg(44.0lb)	10



ZL4-7

Model: ZL4-7

Color: Silver

Materials: Aluminum + Plastic

Packing: Canvas bag

Model	Dimension(W*H)	Packing Size(m)	Gross Weight	Unit/Carton
ZL4-7	0.80m x 1.80m	0.9m x 0.23m x 0.3m	20.0kg(44.0lb)	10
ZL4-7	0.85m x 2.00m	0.9m x 0.23m x 0.3m	21.0kg(46.2lb)	10



ZL3-1

Model: ZL3-1

Color: Black

Materials: Plastic

Packing: PP bag

- Competitive price
- Ideal table top style display

Model	Dimension(W*H)	Packing Size(m)	Gross Weight	Unit/Carton
ZL3-1	0.20m x 0.42m	0.43m x 0.27m x 0.31m	7kg(15.4lb)	100

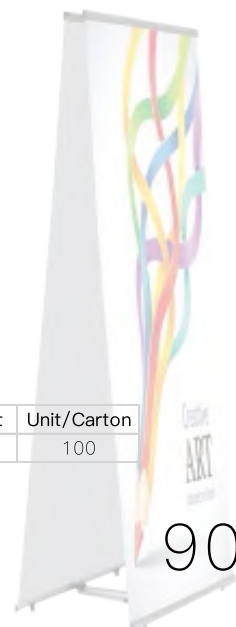

Eastsign Banner Stands

Model: ZL1-9

Color: Silver

Materials: Aluminum

Packing: Carton Box

Model	Dimension	Packing Size(m)	Gross Weight	Unit/Carton
ZL1-9	A4/A3,SINGLE	0.5m x 0.27m x 0.45m	15kg(33.0lb)	50



ZL1-9



ZL1-9-2

Model: ZL1-9-2

Color: Silver

Materials: Aluminum

Packing: Carton Box

Model	Dimension	Packing Size(m)	Gross Weight	Unit/Carton
ZL1-9-2	A4/A3,DOUBLE	0.5m x 0.3m x 0.45m	18kg(39.6lb)	50



ZL1-L-T1

Model: ZL1-L-T1

Color: Silver

Materials: Aluminum

Packing: Carton Box

Model	Dimension	Packing Size(m)	Gross Weight	Unit/Carton
ZL-L-T1	A4/A3,SINGLE	0.43m x 0.27m x 0.31m	9kg(19.8lb)	50



ZL1-L-T2

Model: ZL1-L-T2

Color: Silver

Materials: Aluminum

Packing: Carton Box

Model	Dimension	Packing Size(m)	Gross Weight	Unit/Carton
ZL-L-T2	A4/A3,DOUBLE	0.43m x 0.27m x 0.31m	11kg(24.2lb)	50



Eastsign

Brochure Stands

Model: ZL14-4A

Square Base

Color: Silver

Materials: Acrylic

Packing: Canvas bag

● Pop-up design for fast set-up

● Excellent material shelf for indoor purposes

Model	Dimension	Packing Size(m)	Gross Weight	Unit/Carton	Remarks
ZL14-4A	A4, four layers	0.43m x 0.27m x 0.31m	13kg(28.6lb)	1	Canvas bag



ZL14-4A



ZL14-7

Model: ZL14-7

Square Base

Color: Silver

Materials: Acrylic

Packing: Canvas bag

● Pop-up design for fast set-up

● Excellent material shelf for indoor purposes

Model	Dimension	Packing Size(m)	Gross Weight	Unit/Carton	Remarks
ZL14-7	A4, four layers	0.51 m x 0.39m x 0.21m	10kg(22.0lb)	1	Canvas bag



ZL14-6

Model: ZL14-6

Color: Grey

Materials: Iron

Packing: Canvas bag

● Heavy Duty

● Portable

● Excellent material shelf for indoor purposes

● Smart appearance

Model	Dimension	Packing Size(m)	Gross Weight	Unit/Carton	Remarks
ZL14-6	A4, four layers	0.43m x 0.54m x 0.31m	21kg(46.2lb)	1	Canvas bag



ZL14-2

Model: ZL14-2

Square Base

Color: Silver

Materials: Acrylic

Packing: Canvas bag

● Pop-up design for fast set-up

● Excellent material shelf for indoor purposes

Model	Dimension	Packing Size(m)	Gross Weight	Unit/Carton	Remarks
ZL14-2	A4, Double-line	0.43m x 0.54m x 0.31m	15kg(33.0lb)	8	Canvas bag



ZL14-3A

Model: ZL14-3A

Square Base

Color: Silver

Materials: Acrylic

Packing: Canvas bag

● Pop-up design for fast set-up

● Excellent material shelf for indoor purposes

Model	Dimension	Unit/Carton	Remarks
ZL14-3A	A4, six layers	1	ALUminium case OR Canvas bag



Eastsign

Post Stands

Model: ZL15-2

Color: Silver

Materials: Aluminum Frame

Packing: Carton box

Unit/Carton: 1 pcs

- Flexible in adjusting the height
- Customized size is available upon request

Model	Dimension	Packing Size(m)	Gross Weight
ZL 15-2A	A4	0.94m x 0.07m x 0.33m	4.0kg(8.8lb)
ZL 15-2B	A3	0.94m x 0.07m x 0.42m	4.5kg(9.9lb)



ZL15-2



ZL15-3

Model: ZL15-3

Color: Silver

Materials: Aluminum

Packing: Carton box

- Flexible in adjusting the height
- Easy to set up

Model	Dimension	Packing Size(m)	Gross Weight	Unit/Carton
ZL 15-3A	A4 or A3	0.9m x 0.08m x 0.35m	3.5kg(7.7lb)	1
ZL 15-3B	A4 or A3	0.9m x 0.08m x 0.40m	4kg(8.8lb)	1



ZL15-4

Model: ZL15-4

Color: Silver

Materials: Aluminum + Acrylic

Packing: Carton box

- Flexible in adjusting the height
- Easy to set up

Model	Dimension	Packing Size(m)	Gross Weight	Unit/Carton
ZL 15-4	A4	0.9m x 0.08m x 0.35m	3.5kg(7.7lb)	1



Eastsign

Outdoor Sign Stands

Model: ZL7-2A(Single-sided)

Color: Silver

Materials: Aluminum

Packing: Carton Box

● Easy to set up

● Adapt to various picture size

Model	Dimension	Packing Size(m)	Gross Weight	Unit / Carton
ZL7-2A	0.6m x 0.84m	1.22m x 0.12m x 0.68m	5.0kg(11.0lb)	1



ZL7-2A



ZL7-1A

Model: ZL7-1A (Double-sided)

Color: Silver

Materials: Aluminum + MDF board

Packing: Carton Box

● Double side presentation

● Solid and stable

● Protection film on rigid PVC

Model	Dimension	Packing Size(m)	Gross Weight	Unit / Carton
ZL7-1A	0.6m x 0.84m	1.22m x 0.12m x 0.68m	6.0kg(13.2lb)	1



ZL7-4

Model: ZL7-4 (Double-sided)

Color: Silver

Materials: Aluminum/Iron

Packing: Carton Box

● Double side presentation

● Solid Iron base

● Protection film on rigid PVC

Model	Dimension	Packing Size(m)	Gross Weight	Unit / Carton
ZL7-4	0.6m x 0.84m, Steel base	1.22m x 0.12m x 0.68m	12.0kg(26.4lb)	1



ZL7-5

Model: ZL7-5(Double-sided)

Color: Silver

Materials: Aluminum

Packing: Carton Box

Feature:

● Double side presentation

● Water filled base

Model	Dimension	Packing Size(m)	Gross Weight	Unit / Carton
ZL7-5	0.6m x 0.84m, water-filling base	1.22m x 0.12m x 0.68m	12.0kg(26.4lb)	1



ZL2-10

Model: ZL2-10(Adjustable)

Color: Silver

Materials: Aluminum + Iron

Packing: Carton Box

● Single side presentation

● Protection film on rigid PVC

Model	Dimension	Packing Size(m)	Gross Weight	Unit / Carton
ZL2-10	1.6m - 2.0m x 1.6m - 2.0m	1.30m x 0.22m x 0.22m	24kg(52.8lb)	4

Eastsign

Promotion Counter Display

Model: ZL-PC-B

Color: Silver

Materials: Aluminum Frame + Magnetic

Packing: Canvas bag

- Strong
- Portable
- Pop-up design for fast set up
- Ideal display for short term applications

Model	Dimension	Packing Size(m)	Unit / Carton
ZL-PC-B	Bean 900X450X900	0.95m x 0.12m x 0.5m	0.5



ZL-PC-B



ZL-PC-D

Model: ZL-PC-D

Color: Silver

Materials: Aluminum Frame + Magnetic

Packing: Canvas bag

- Strong
- Portable
- Pop-up design for fast set up
- Ideal display for short term applications

Model	Dimension	Packing Size(m)	Unit / Carton
ZL-PC-D	Drop 920X450X900	0.95m x 0.12m x 0.5m	0.5



ZL-PC-R

Model: ZL-PC-R

Color: Silver

Materials: Aluminum Frame + Magnetic

Packing: Canvas bag

- Strong
- Portable
- Pop-up design for fast set up
- Ideal display for short term applications

Model	Dimension	Packing Size(m)	Unit / Carton
ZL-PC-R	Round ?450x900	0.5m x 0.12m x 0.5m	0.5



ZL13-3

Model: ZL13-3 Screen Table

Color: Silver

Materials: Aluminum frame + ABS Plastic

Packing: Canvas bag

- Light and strong
- Portable
- Easy to replace the print
- ABS plastic table top
- Ideal front desk for short term application
- Two poles are removable

Model	Dimension	Packing Size(m)	Unit / Carton
ZL13-3	800X350X2000	0.88m x 0.12m x 0.83m	1

Eastsign

Promotion Counter Display

Model: ZL13-9 Pop-up Table

Color: Silver

Materials: Aluminum Frame

Packing: Canvas bag

Gross weight: 11kg or 24.2lb

Unit/carton: 1pcs

- Light and strong
- Portable
- Pop-up design for fast set-up
- Ideal front desk for short term application

Model	Dimension	Packing Size(m)	Unit / Carton
ZL13-9	800X350X2000	1.05m x 0.2m x 0.4m	1



ZL13-10



ZL13-9

Model: ZL13-10

Color: Silver

Materials: Aluminum Frame + Magnetic

Packing: Canvas bag

- Strong
- Portable
- Pop-up design for fast set up
- Ideal display for short term applications

Model	Dimension	Packing Size(m)	Unit / Carton
ZL13-10	1000X370X1000	1.05m x 0.2m x 0.4m	1

Clip Frames



ZL24-E-25R



ZL24-E-25M

Model: ZL24-E-25R

Color: Silver

Materials: Aluminum Frame

Packing: Carton box

- Durable and Elegant
- Easy to set up
- Ultra light
- Other sizes are available

Model	Dimension	Packing Size(m)	Gross Weight	Unit / Carton
ZL24-E-25R	A1	0.93m x 0.27m x 0.68m	28kg(61.6lb)	10pc
ZL24-E-25R	A2	0.68m x 0.27m x 0.50m	16kg(35.2lb)	10pc
ZL24-E-25R	A3	0.50m x 0.27m x 0.37m	12kg(26.4lb)	10pc
ZL24-E-25R	A4	0.37m x 0.27m x 0.39m	10kg(22lb)	10pc

Model: ZL24-E-25M

Color: Silver

Materials: Aluminum Frame

Packing: Carton box

- Durable and Elegant
- Easy to set up
- Ultra light
- Other sizes are available

Model	Dimension	Packing Size(m)	Gross Weight	Unit / Carton
ZL24-E-25M	A1	0.93m x 0.27m x 0.68m	28kg(61.6lb)	10pc
ZL24-E-25M	A2	0.68m x 0.27m x 0.50m	16kg(35.2lb)	10pc
ZL24-E-25M	A3	0.50m x 0.27m x 0.37m	12kg(26.4lb)	10pc
ZL24-E-25M	A4	0.37m x 0.27m x 0.39m	10kg(22lb)	10pc

Eastsign

Clip Frames

Model: ZL24-D-32R

Color: Silver

Materials: Aluminum Frame

Packing: Carton box

- Durable and Elegant
- Easy to set up
- Ultra light
- Other sizes are available
- Mitred corner is available

Model	Dimension	Packing Size(m)	Gross Weight	Unit / Carton
ZL24-D-32R	A1	0.93m x 0.27m x 0.68m	29kg(63.8lb)	10pc
ZL24-D-32R	A2	0.68m x 0.27m x 0.50m	17kg(37.4lb)	10pc
ZL24-D-32R	A3	0.50m x 0.27m x 0.37m	13kg(28.6lb)	10pc
ZL24-D-32R	A4	0.37m x 0.27m x 0.39m	10kg(22lb)	10pc



ZL24-D-32R



ZL24-D-32M



ZL24-I-25

Model: ZL24-D-32M

Color: Silver

Materials: Aluminum Frame

Packing: Carton box

- Durable and Elegant
- Easy to set up
- Ultra light
- Other sizes are available
- Mitred corner is available

Model	Dimension	Packing Size(m)	Gross Weight	Unit / Carton
ZL24-D-32M	A1	0.93m x 0.27m x 0.68m	29kg(63.8lb)	10pc
ZL24-D-32M	A2	0.68m x 0.27m x 0.50m	17kg(37.4lb)	10pc
ZL24-D-32M	A3	0.50m x 0.27m x 0.37m	13kg(28.6lb)	10pc
ZL24-D-32M	A4	0.37m x 0.27m x 0.39m	10kg(22lb)	10pc

Model: ZL24-I-25

Color: Silver

Materials: Aluminum Frame

Packing: Carton box

- Durable and Elegant
- Easy to set up
- Ultra light

Model	Dimension	Packing Size(m)	Gross Weight	Unit / Carton
ZL24-I-25	A2	0.68m x 0.27m x 0.50m	14kg(30.8lb)	10pc
ZL24-I-25	A3	0.50m x 0.27m x 0.37m	10kg(22.0lb)	10pc
ZL24-I-25	A4	0.37m x 0.27m x 0.39m	7kg(15.4lb)	10pc



ZL24-F-10

Model: ZL24-F-10

Color: Silver

Materials: Aluminum Frame

Packing: Carton box

- Durable and Elegant
- Easy to set up
- Ultra light

Model	Dimension	Packing Size(m)	Gross Weight	Unit / Carton
ZL24-F-10	A1	0.93m x 0.27m x 0.68m	25kg(55.0lb)	10pc
ZL24-F-10	A2	0.68m x 0.27m x 0.50m	17kg(37.4lb)	10pc
ZL24-F-10	A3	0.50m x 0.27m x 0.37m	13kg(28.6lb)	10pc
ZL24-F-10	A4	0.37m x 0.27m x 0.39m	10kg(22lb)	10pc

Eastsign

Pop Up Displays



Model: ZL2-2E1

Color: Silver

Materials: Aluminum

Packing: Canvas trolley

- Strong and stable
- Straight or curve
- Plastic trolley is available
- Velcro model available

Model	Dimension	Packing Size(m)	Gross Weight	Unit/Carton
ZL2-2E1	2.3m x 2.3m 3x3,spring	0.45m x 0.45m x 0.94m	32kg(70.4lb)	1
ZL2-2E2	3.0m x 2.3m 4x3 spring	0.45m x 0.45m x 0.94m	35kg(77.0lb)	1



ZL2-2E1



ZL2-6-S

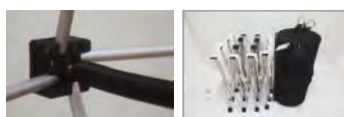

Model: ZL2-6-S

Color: Silver

Materials: Aluminum

Packing: Canvas trolley

- Luxury Type
- Best choice for tight budget
- Straight or curve
- Plastic trolley is available
- Velcro model available

Model	Dimension	Packing Size(m)	Gross Weight	Unit/Carton
ZL2-6-S	2.3m x 2.3m 3x3 fabric	0.45m x 0.45m x 0.94m	32kg(70.4lb)	1
ZL2-6-S	3.0m x 2.3m 4x3 fabric	0.45m x 0.45m x 0.94m	35kg(77.0lb)	1



ZL2-6-P



Model: ZL2-6-P

Color: Silver

Materials: Aluminum+Plastic+magnetic

Packing: Canvas Bag

- For HIPS graphics

Model	Dimension	Packing Size(m)	Gross Weight	Unit/Carton
ZL2-6-P	2.3m x 2.3m 3x3 fabric	0.45m x 0.45m x 0.94m	32kg(70.4lb)	1
ZL2-6-P	3.0m x 2.3m 4x3 fabric	0.45m x 0.45m x 0.94m	35kg(77.0lb)	1



Eastsign Flying Banners

Model: ZL6-13-F

Color: Silver

Materials: Aluminum

Packing: Canvas bag

- Insert type stand
- Easy to set up

Model	Dimension	Packing Size(m)	Gross Weight	Unit / Carton
ZL6-13-F	H:2.8m	0.17m x 0.24m x 1.07m	16.0kg(35.2lb)	10
ZL6-13-F	H:3.5m	0.17m x 0.24m x 1.27m	17.0kg(37.4lb)	10
ZL6-13-F	H:4.5m	0.17m x 0.24m x 1.27m	19.5kg(42.9lb)	10



ZL6-13-F



ZL6-13-H

Model: ZL6-13-H

Color: Silver

Materials: Aluminum

Packing: Canvas bag

- Insert type stand
- Easy to set up

Model	Dimension	Packing Size(m)	Gross Weight	Unit / Carton
ZL6-13-H	H:2.5m	0.17m x 0.24m x 1.07m	18.5kg(40.7lb)	10
ZL6-13-H	H:3.5m	0.17m x 0.24m x 1.27m	19.0kg(41.8lb)	10
ZL6-13-H	H:4.5m	0.17m x 0.24m x 1.27m	24.0kg(52.8lb)	10



ZL6-13-S

Model: ZL6-13-S

Color: Silver

Materials: Aluminum

Packing: Canvas bag

- Insert type stand
- Easy to set up

Model	Dimension	Packing Size(m)	Gross Weight	Unit / Carton
ZL6-13-S	H:2.8m	0.17m x 0.24m x 1.07m	16.0kg(35.2lb)	10
ZL6-13-S	H:3.5m	0.17m x 0.24m x 1.27m	17.0kg(37.4lb)	10
ZL6-13-S	H:4.5m	0.17m x 0.24m x 1.27m	19.5kg(42.9lb)	10



ZL6-10

Model: ZL6-10

Color: Silver

Materials: Aluminum

Packing: Canvas bag

- Insert type stand
- Easy to set up

Model	Dimension	Packing Size(m)	Gross Weight	Unit / Carton
ZL6-10	1.0m x 5.0m	0.85m x 0.5m x 0.65m	9.0kg(19.8lb)	0.5



G1



G2



G3



SB



CF



C2

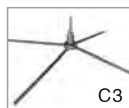

C3

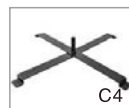

C4



PWB



WB